

Pump Data

Brand : JMS
 Model : JIGER 70 M
 Head Rate: 18 FEET Flow Rate: 30 GPM
 Head Max: 31 FEET Flow Max: 57 GPM
 Head Min: 3 FEET Flow Min: 5 GPM
 RPM : 3450 rpm
 Normal Power P1 : 1.5 HP
 Fluid: Water
 Fluid Temperature: at about 25 °C.
 Density: water 1.0 kg/Dm³
 Fluid Viscosity: 8.90 × 10⁻⁴ Pa·s
 With Float switch: NONE
 Kind of Workiny: Submersible
 Delivery size: 1" 1/2 NPT
 Suction size: With Strainer
 Made in : ITALY

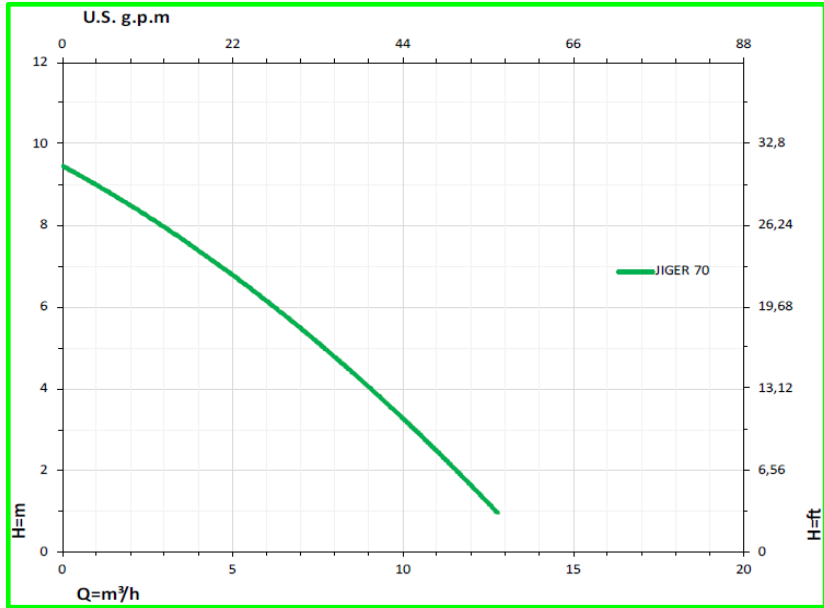

Motor Data

Power P2:
 Power P1: 1.1 KW
 Phase (PH): 1
 Rate Voltage : 230 V
 Capacitor Need : 16 μF
 Ferequency : 60 Hz
 Rated Speed (rpm): 3450 rpm
 Max. I (A): 5.5 A
 Cos φ : 0.95
 Degree of Protection (IP): IP 68
 Safety Protection Included: F
 length of Cable : 10 M
 Kind of Plug : NONE
 Ambient Temp : 40°C = 104°F

Other Pump Data

Impeller Size (mm) : *
 Pressuer Rating : PN 16
 Min. Fluid Temp : 10°C = 50°F
 Max. Fluid Temp : 35°C = 95°F
 Ambient Temp : 40°C = 104°F
 Humidity % : 100%

Special Specification

Installation status : Vertical
 Variable frequency : NONE
 Solid Passage 30 mm

Materials

Pump Body : CAST IRON
 Support: Stainless steel
 Impeller: CAST IRON
 Mechanical Seal: Silicon Carbide
 Rubber: NBR
 Pump Shaft: Stainless steel
 Strainer: Stainless steel
 outer cover: CAST IRON
 Motor Case: Stainless steel

Shaft Seal

Type: *
 Stationary Part: Silicon Carbide
 Rotating Part: Silicon Carbide
 Elastomer: NBR

Pump and Motor specification optional

With Booster System: None
 With Complack: None
 Special Material: None
 Speacil Voltage: None

Protection system required

External Flout switch: YES
 Minimum Starter: Starter SWT

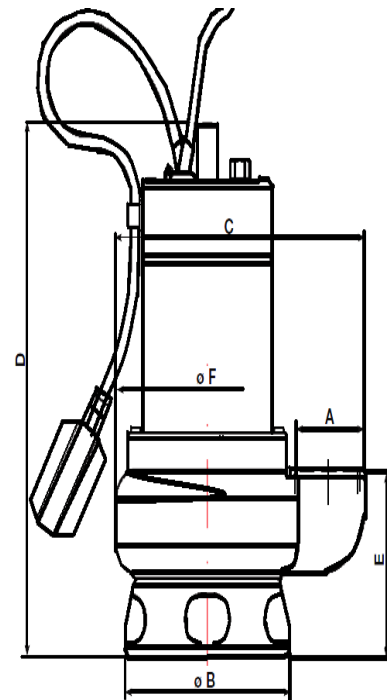

Weight : 13.5 Kg

Standard Approve

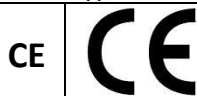

Applicant:

Decantation Pit Sewage Pit and Slurry
 Collection Pit Pump out Pump out of Lavatory
 Foul Water with Possible Floating
 Domestic and Industrial Lavatory
 Black Water Handling Systems

Dimention in

mm
A 1 1/2"
B 150
C 232
D 360.5
E 125
F 170