



G.P.T. CO

X SERIES

6" - 7" - 8" - 10"

**STAINLESS STEEL
PUMPS**



2015/06



60 Hz



G.P.T. CO



STAINLESS STEEL SUBMERSIBLE PUMPS **60 HZ**



G•P•T• CO

- Long life
- High efficiency
- High durability and solid construction
- Easy service operation
- Suitable connection in NEMA standards
- Water lubricated rubber bearing
- Built-in checkvalve to prevent back flow

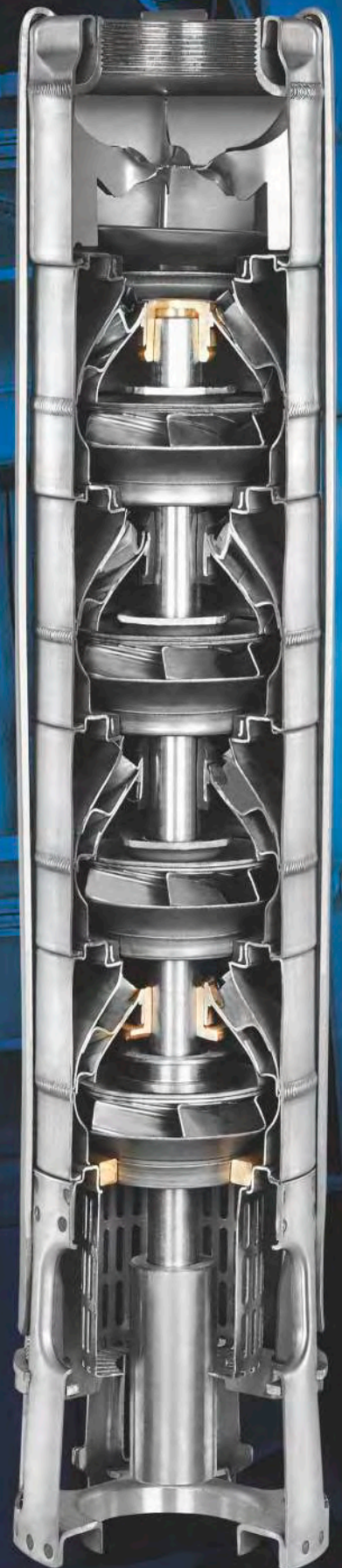

General Information

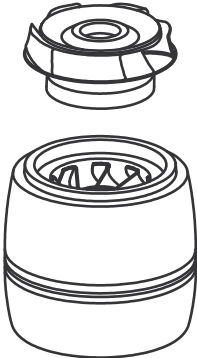

Manufacturing stainless steel of; Diffusers, impellers, suction case, discharge case provides maximum strength, durability, wear and tear resistance.



Rubber bearings are water lubricated and have sand channels to make enable the sand particles leave the pump with the pumped liquid.

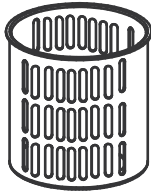

The stainless steel strainer prevents particles over a certain size from entering the pump.

Product Code System

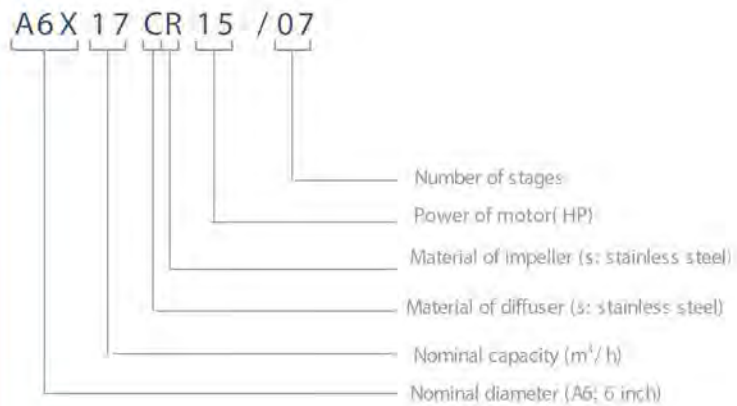

Part List

No	Part Name	Material
1	Suction Case	Stainless Steel (AISI 340L)
2	Filter	Stainless Steel (AISI 340)
3	Suction Case Wear Ring	Bronze (ASTM B145-4A)
4	Pump Shaft With Coupling	Stainless Steel (AISI 420)
5	Collet	Stainless Steel
6	Impeller Wear Rings	Stainless Steel (ASI 304)
7	Impeller	Stainless Steel (ASI 304L)
8	Diffuser	Stainless Steel (AISI 304L)
9	Rubber Bearing	Rubber
10	Diffuser Wear Ring	Rubber
11	Nut For Stop Ring	Stainless Steel (AISI 304L)
12	Bearing	Rubber
13	Shaft Stopper	Bronze (ASTM B145-4A)
14	Valve	Stainless Steel (AISI 304)
15	Discharge Case	Stainless Steel (AISI 304)
16	Tie Rod	Stainless Steel (AISI 304L)
17	Cable Guard	Stainless Steel (AISI 304)
18	Tie Rod Nut	Stainless Steel (AISI 303)
19	Name Plate	Stainless Steel (AISI 304)



G.P.T. CO

Technical Drawing

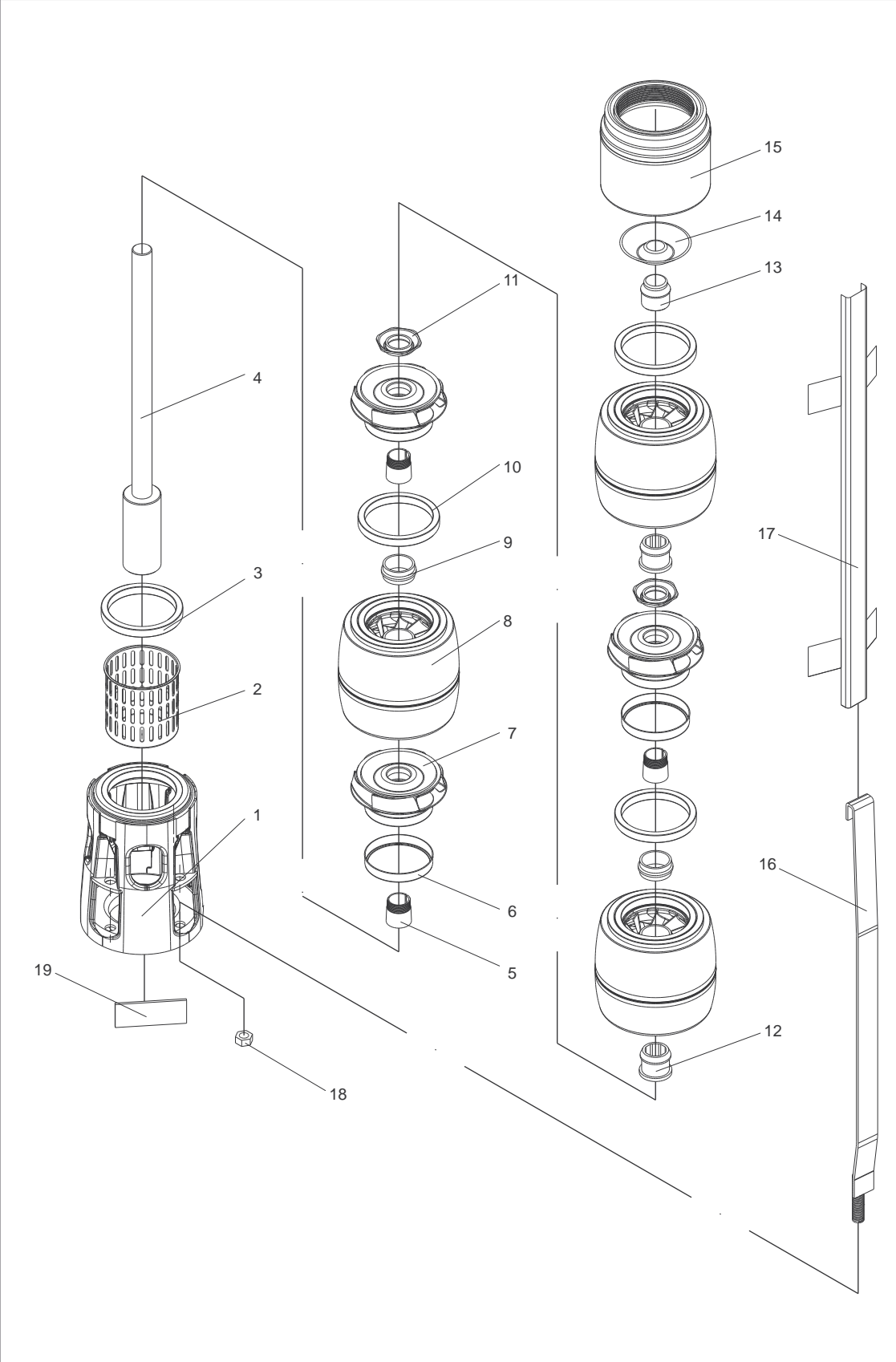

Technical specifications

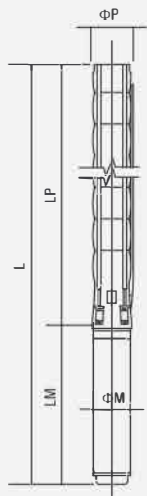

- Diffuser : Stainless steel (AISI 304L)
- Impeller : Stainless steel (AISI 304L)
- Pump shaft : Stainless steel (AISI 420)
- Coupling : Stainless steel (AISI 420)
- Strainer : Stainless steel (AISI 304)
- Outlet connection diameter : 2 1/2" (inside threaded)

- Max. sand content : 50 gr / m³
- Valve cap : Stainless steel
- Voltage : 460 V (+ %6 / -%10)
- Frequency : 60 Hz.
- Max. water temperature : 30°C (50°C optional)
- Degree of protection : IP 68



Pump type	Stages	Power		Dimensions (in)					Weight (lb)		
		kW	HP	L	LM	LP	ΦM	ΦP	Motor	Pump	Total
A6X 10 CR 05/05	5	4	5,5	48	26	23	6	5	88	24	112
A6X 10 CR 05/06	6	4	5,5	50	26	25	6	5	88	29	117
A6X 10 CR 05/07	7	4	5,5	53	26	27	6	5	88	31	119
A6X 10 CR 07/08	8	5,5	7,5	56	27	30	6	5	96	33	129
A6X 10 CR 07/09	9	5,5	7,5	59	27	32	6	5	96	37	133
A6X 10 CR 07/10	10	5,5	7,5	61	27	34	6	5	96	40	136
A6X 10 CR 10/11	11	7,5	10	67	30	37	6	5	110	44	154
A6X 10 CR 10/12	12	7,5	10	69	30	39	6	5	110	46	157
A6X 10 CR 10/13	13	7,5	10	71	30	42	6	5	110	51	161
A6X 10 CR 12/14	14	9,3	12,5	75	31	44	6	5	121	53	174
A6X 10 CR 12/15	15	9,3	12,5	78	31	46	6	5	121	57	179
A6X 10 CR 12/16	16	9,3	12,5	80	31	49	6	5	121	60	181
A6X 10 CR 15/17	17	11	15	85	34	51	6	5	132	62	194

Pump type	Stages	Power		Current (A)	gal/h	Head (ft)												
		kW	HP			1057	2113	3170	3698	4227	4755	5283	5812					
						1,11	2,22	3,33	3,89	4,44	5,00	5,56	6,11					
A6X 10 CR 05/05	5	4	5,5	8,4	Head (ft)	220	213	194	177	161	138	112	85					
A6X 10 CR 05/06	6	4	5,5	8,4		266	256	230	213	190	164	135	102					
A6X 10 CR 05/07	7	4	5,5	8,4		308	299	269	249	223	194	157	118					
A6X 10 CR 07/08	8	5,5	7,5	11,3		354	338	308	285	256	220	180	138					
A6X 10 CR 07/09	9	5,5	7,5	11,3		397	381	348	318	285	249	203	154					
A6X 10 CR 07/10	10	5,5	7,5	11,3		440	423	384	354	318	276	226	171					
A6X 10 CR 10/11	11	7,5	10	14,2		486	466	423	390	351	305	249	187					
A6X 10 CR 10/12	12	7,5	10	14,2		528	509	463	427	384	331	272	203					
A6X 10 CR 10/13	13	7,5	10	14,2		574	551	499	463	413	358	295	220					
A6X 10 CR 12/14	14	9,3	12,5	17,4		617	594	538	499	446	387	318	240					
A6X 10 CR 12/15	15	9,3	12,5	17,4		663	636	577	531	479	413	338	256					
A6X 10 CR 12/16	16	9,3	12,5	17,4		705	679	617	568	512	443	361	272					
A6X 10 CR 15/17	17	11	15	19,6		748	722	653	604	541	469	384	289					

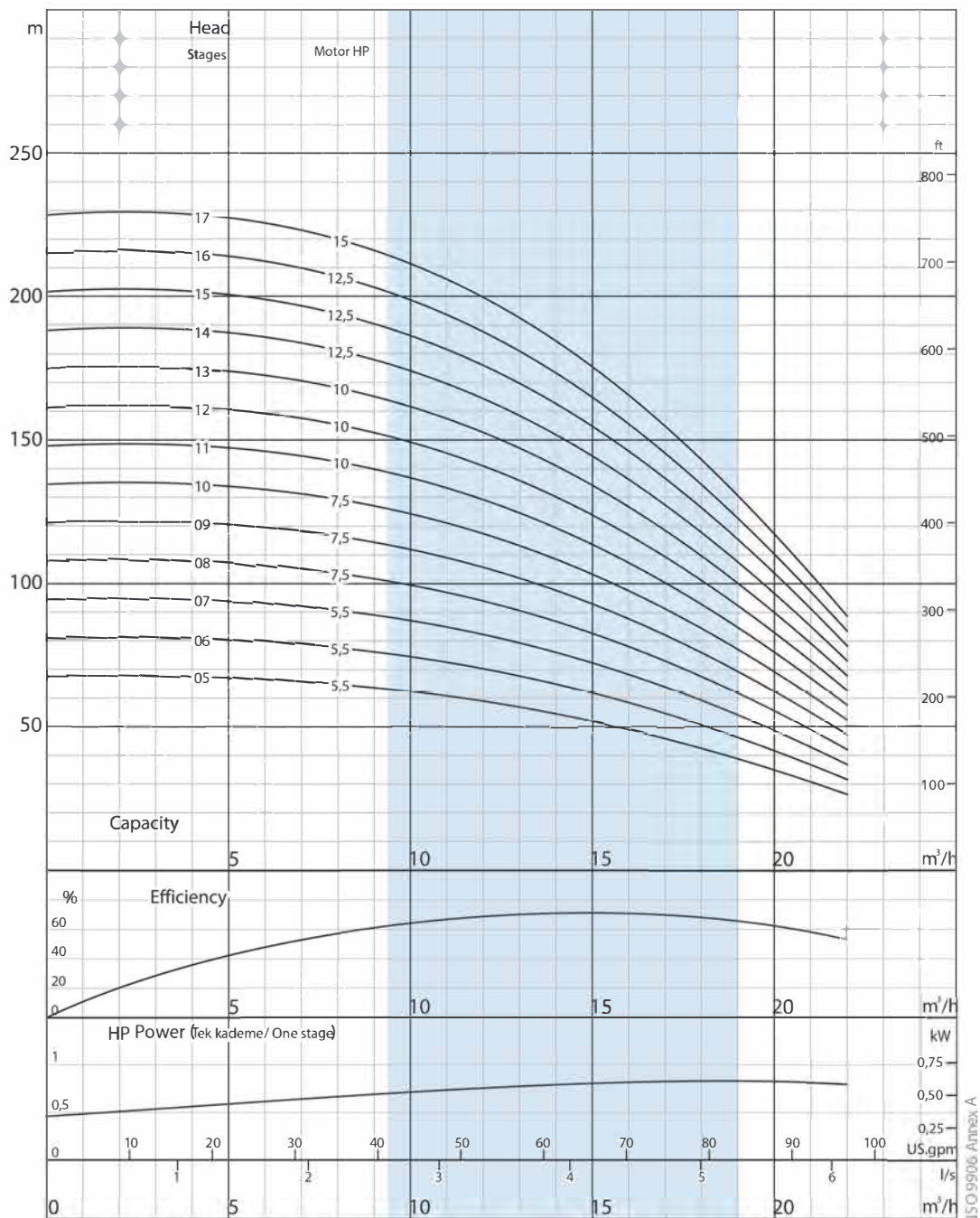

Due to continuous improvement in design we reserve the right to amend specifications or data without prior notice.

A6X 10 CR

No. of vanes
6

Outlet connection diameter
2 1/2" (inside threaded)

Pump outside diameter
132 mm

Rotation
CCW

Revolution
3500 rpm

Shaft diameter
20 mm

The hydraulic working characteristics have been taken with water at 15 °C, at the atmospheric pressure of 1 bar and specific gravity is 1 gr/cm³



ISO 9906 Annex A

Technical specifications

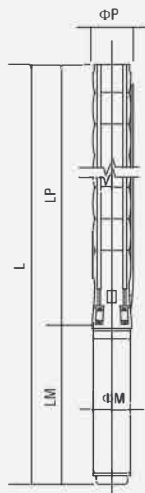

- Diffuser** : Stainless steel (AISI 304L)
- Impeller** : Stainless steel (AISI 304L)
- Pump shaft** : Stainless steel (AISI 420)
- Coupling** : Stainless steel (AISI 420)
- Strainer** : Stainless steel (AISI 304)
- Outlet connection diameter** : 2 1/2" (inside threaded)

- Max. sand content** : 50 gr / m³
- Valve cap** : Stainless steel
- Voltage** : 460 V (+%6 / -%10)
- Frequency** : 60 Hz.
- Max. water temperature** : 30°C (50°C optional)
- Degree of protection** : IP 68



Pump type	Stages	Power		Dimensions (in)					Weight (lb)		
		kW	HP	L	LM	LP	ΦM	ΦP	Motor	Pump	Total
A6X 10 CR 15/18	18	11	15	87	34	53	6	5	132	66	198
A6X 10 CR 15/19	19	11	15	89	34	56	6	5	132	68	201
A6X 10 CR 15/20	20	11	15	92	34	58	6	5	132	73	205
A6X 10 CR 17/21	21	13	17,5	96	36	61	6	5	143	75	218
A6X 10 CR 17/22	22	13	17,5	99	36	63	6	5	143	79	223
A6X 10 CR 17/23	23	13	17,5	101	36	65	6	5	143	82	225
A6X 10 CR 20/24	24	15	20	106	38	68	6	5	159	86	245
A6X 10 CR 20/25	25	15	20	108	38	70	6	5	159	88	247
A6X 10 CR 20/26	26	15	20	111	38	73	6	5	159	90	249
A6X 10 CR 20/27	27	15	20	113	38	75	6	5	159	95	254
A6X 10 CR 25/28	28	18,5	25	117	40	77	6	5	168	97	265
A6X 10 CR 25/29	29	18,5	25	119	40	80	6	5	168	101	269
* A6X 10 CR 25/30	30	18,5	25	122	40	82	6	7	168	165	333
* A6X 10 CR 25/31	31	18,5	25	124	40	84	6	7	168	168	335
* A6X 10 CR 25/32	32	18,5	25	126	40	87	6	7	168	172	340
* A6X 10 CR 25/33	33	18,5	25	129	40	89	6	7	168	176	344
* A6X 10 CR 25/34	34	18,5	25	131	40	92	6	7	168	181	348

Pump type	Stages	Power		Current (A)	gal/h	Head (ft)	1057	2113	3170	3698	4227	4755	5283	5812
		kW	HP				1,11	2,22	3,33	3,89	4,44	5,00	5,56	6,11
A6X 10 CR 15/18	18	11	15	19,6			794	764	692	640	574	495	407	305
A6X 10 CR 15/19	19	11	15	19,6			837	807	732	676	607	525	430	325
A6X 10 CR 15/20	20	11	15	19,6			883	850	768	712	636	551	453	341
A6X 10 CR 17/21	21	13	17,5	23,4			925	892	807	745	669	581	476	358
A6X 10 CR 17/22	22	13	17,5	23,4			971	932	846	781	702	607	499	374
A6X 10 CR 17/23	23	13	17,5	23,4			1014	974	886	817	735	633	522	390
A6X 10 CR 20/24	24	15	20	27,3			1060	1017	922	853	764	663	545	410
A6X 10 CR 20/25	25	15	20	27,3			1102	1060	961	889	797	689	564	427
A6X 10 CR 20/26	26	15	20	27,3			1145	1102	1001	922	830	719	587	443
A6X 10 CR 20/27	27	15	20	27,3			1191	1145	1040	958	860	745	610	459
A6X 10 CR 25/28	28	18,5	25	34,5			1234	1188	1076	994	892	774	633	476
A6X 10 CR 25/29	29	18,5	25	34,5			1280	1230	1115	1030	925	801	656	495
* A6X 10 CR 25/30	30	18,5	25	34,5			1322	1273	1155	1066	958	827	679	512
* A6X 10 CR 25/31	31	18,5	25	34,5			1368	1316	1191	1102	988	856	702	528
* A6X 10 CR 25/32	32	18,5	25	34,5			1411	1358	1230	1135	1020	883	725	545
* A6X 10 CR 25/33	33	18,5	25	34,5			1457	1401	1270	1171	1053	912	748	561
* A6X 10 CR 25/34	34	18,5	25	34,5			1499	1444	1309	1207	1086	938	771	577

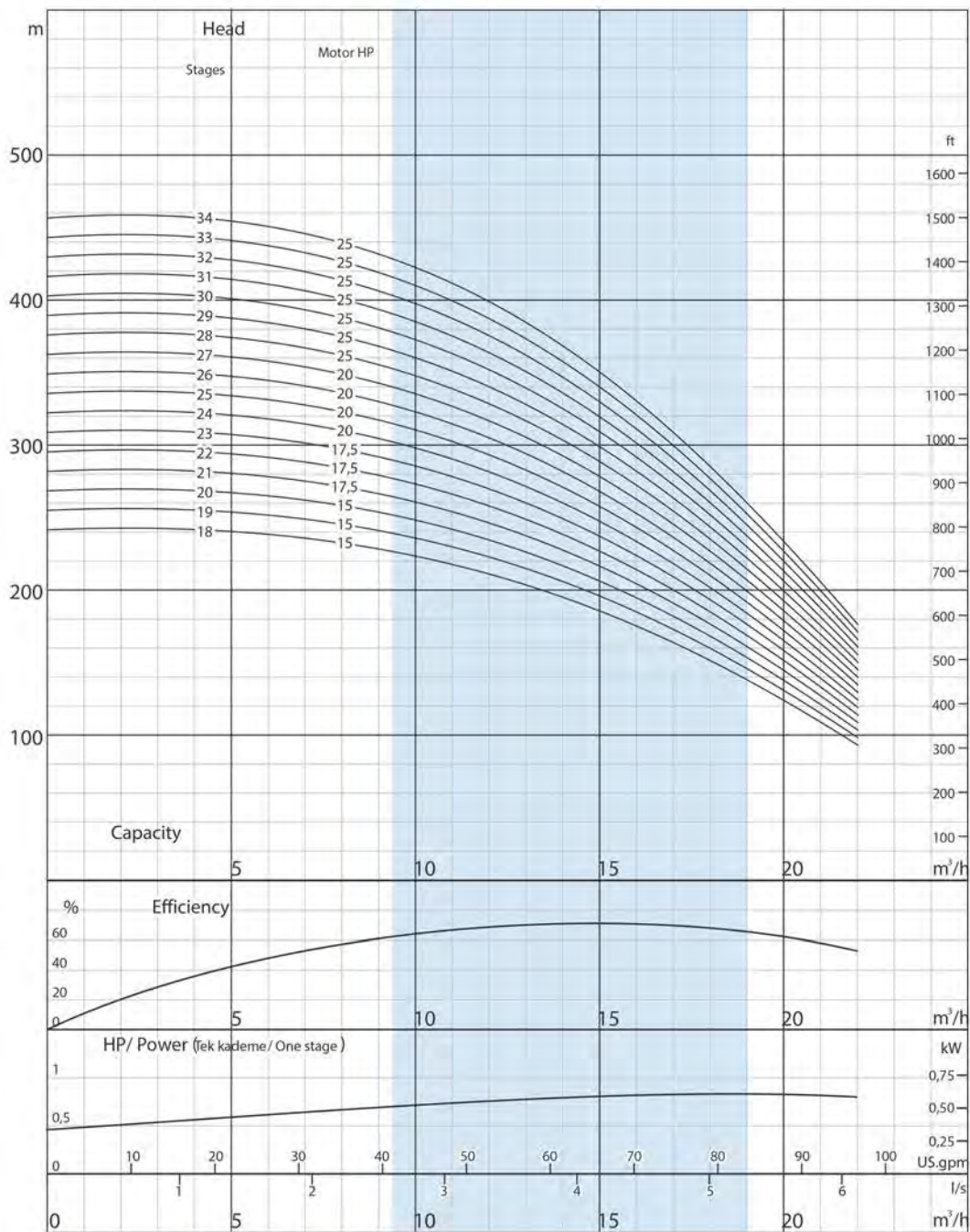

ISO 9906 Annex A

Due to continuous improvement in design we reserve the right to amend specifications or data without prior notice.

A6X 10 CR

No. of vanes
6

Outlet connection diameter
2 1/2" (inside threaded)

Pump outside diameter
132 mm

Rotation
CCW

Revolution
3500 rpm

Shaft diameter
20 mm

The hydraulic working characteristics have been taken with water at 15 °C, at the atmospheric pressure of 1 bar and specific gravity is 1 gr/cm³



Technical specifications

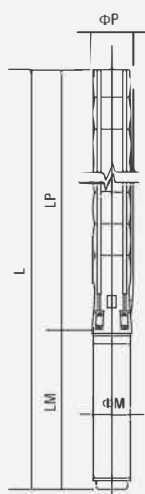

- Diffuser** : Stainless steel (AISI 304L)
- Impeller** : Stainless steel (AISI 304L)
- Pump shaft** : Stainless steel (AISI 420)
- Coupling** : Stainless steel (AISI 420)
- Strainer** : Stainless steel (AISI 304)
- Outlet connection diameter** : 2 1/2" (inside threaded)

- Max. sand content** : 50 gr / m³
- Valve cap** : Stainless steel
- Voltage** : 460 V (+%6 / -%10)
- Frequency** : 60 Hz.
- Max. water temperature** : 30°C (50°C optional)
- Degree of protection** : IP 68



Pump type	Stages	Power		Dimensions (in)					Weight (lb)		
		kW	HP	L	LM	LP	ΦM	ΦP	Motor	Pump	Total
* A6X 10 CR 30/35	35	22	30	138/129	44/35	94	6/7	7	192/190	183	375/373
* A6X 10 CR 30/36	36	22	30	140/131	44/35	96	6/7	7	192/190	187	379/377
* A6X 10 CR 30/37	37	22	30	142/134	44/35	99	6/7	7	192/190	192	384/381
* A6X 10 CR 30/38	38	22	30	145/136	44/35	101	6/7	7	192/190	196	388/386
* A6X 10 CR 30/39	39	22	30	147/139	44/35	104	6/7	7	192/190	201	392/390
* A6X 10 CR 30/40	40	22	30	149/141	44/35	106	6/7	7	192/190	203	395/392
* A6X 10 CR 30/41	41	22	30	152/143	44/35	108	6/7	7	192/190	207	399/397
* A6X 10 CR 35/42	42	26,5	35	159/148	48/37	111	6/7	7	216/201	212	428/412
* A6X 10 CR 35/43	43	26,5	35	161/150	48/37	113	6/7	7	216/201	216	432/417
* A6X 10 CR 35/44	44	26,5	35	163/152	48/37	115	6/7	7	216/201	220	437/421
* A6X 10 CR 35/45	45	26,5	35	166/155	48/37	118	6/7	7	216/201	223	439/423
* A6X 10 CR 35/46	46	26,5	35	168/157	48/37	120	6/7	7	216/201	227	443/428
* A6X 10 CR 35/47	47	26,5	35	170/160	48/37	123	6/7	7	216/201	231	448/432
* A6X 10 CR 35/48	48	26,5	35	173/162	48/37	125	6/7	7	216/201	236	452/437
* A6X 10 CR 40/49	49	30	40	176/166/169	48/37/42	127	6/7	7	227/227/284	238	465/465/522
* A6X 10 CR 40/50	50	30	40	179/168/171	48/37/42	130	6/7	7	227/227/284	243	470/470/527
* A6X 10 CR 40/51	51	30	40	181/171/174	48/37/42	132	6/7	7	227/227/284	247	474/474/531
* A6X 10 CR 40/52	52	30	40	184/173/176	48/37/42	134	6/7	7	227/227/284	251	478/478/536
* A6X 10 CR 40/53	53	30	40	186/175/178	48/37/42	137	6/7	7	227/227/284	256	483/483/540
* A6X 10 CR 40/54	54	30	40	188/178/181	48/37/42	139	6/7	7	227/227/284	258	485/485/542
* A6X 10 CR 40/55	55	30	40	191/180/183	48/37/42	142	6/7	7	227/227/284	262	489/489/547

Pump type	Stages	Power		Current (A)	gal/h	l/s	Head (ft)	1057	2113	3170	3698	4227	4755	5283	5812
		kW	HP					1,11	2,22	3,33	3,89	4,44	5,00	5,56	6,11
* A6X 10 CR 30/35	35	22	30	35				1542	1486	1345	1243	1115	965	791	597
* A6X 10 CR 30/36	36	22	30	35				1588	1526	1385	1280	1148	994	814	614
* A6X 10 CR 30/37	37	22	30	35				1631	1568	1424	1316	1181	1020	837	630
* A6X 10 CR 30/38	38	22	30	35				1677	1611	1463	1348	1211	1050	860	646
* A6X 10 CR 30/39	39	22	30	35				1719	1654	1499	1385	1243	1076	883	663
* A6X 10 CR 30/40	40	22	30	40				1765	1696	1539	1421	1276	1102	906	682
* A6X 10 CR 30/41	41	22	30	40				1808	1739	1578	1457	1309	1132	928	699
* A6X 10 CR 35/42	42	26,5	35	40				1850	1781	1614	1493	1339	1158	951	715
* A6X 10 CR 35/43	43	26,5	35	40				1896	1824	1654	1529	1371	1188	974	732
* A6X 10 CR 35/44	44	26,5	35	40				1939	1867	1693	1562	1404	1214	994	748
* A6X 10 CR 35/45	45	26,5	35	40				1985	1909	1732	1598	1434	1240	1017	768
* A6X 10 CR 35/46	46	26,5	35	50				2028	1952	1768	1634	1467	1270	1040	784
* A6X 10 CR 35/47	47	26,5	35	50				2073	1995	1808	1670	1499	1296	1063	801
* A6X 10 CR 35/48	48	26,5	35	50				2116	2037	1847	1706	1532	1325	1086	817
* A6X 10 CR 40/49	49	30	40	50				2162	2080	1883	1739	1562	1352	1109	833
* A6X 10 CR 40/50	50	30	40	50				2205	2123	1923	1775	1594	1381	1132	850
* A6X 10 CR 40/51	51	30	40	50				2247	2162	1962	1811	1627	1407	1155	869
* A6X 10 CR 40/52	52	30	40	50				2293	2205	2001	1847	1660	1434	1178	886
* A6X 10 CR 40/53	53	30	40	50				2336	2247	2037	1883	1690	1463	1201	902
* A6X 10 CR 40/54	54	30	40	50				2382	2290	2077	1919	1722	1490	1220	919
* A6X 10 CR 40/55	55	30	40	50				2425	2333	2116	1952	1755	1519	1243	935

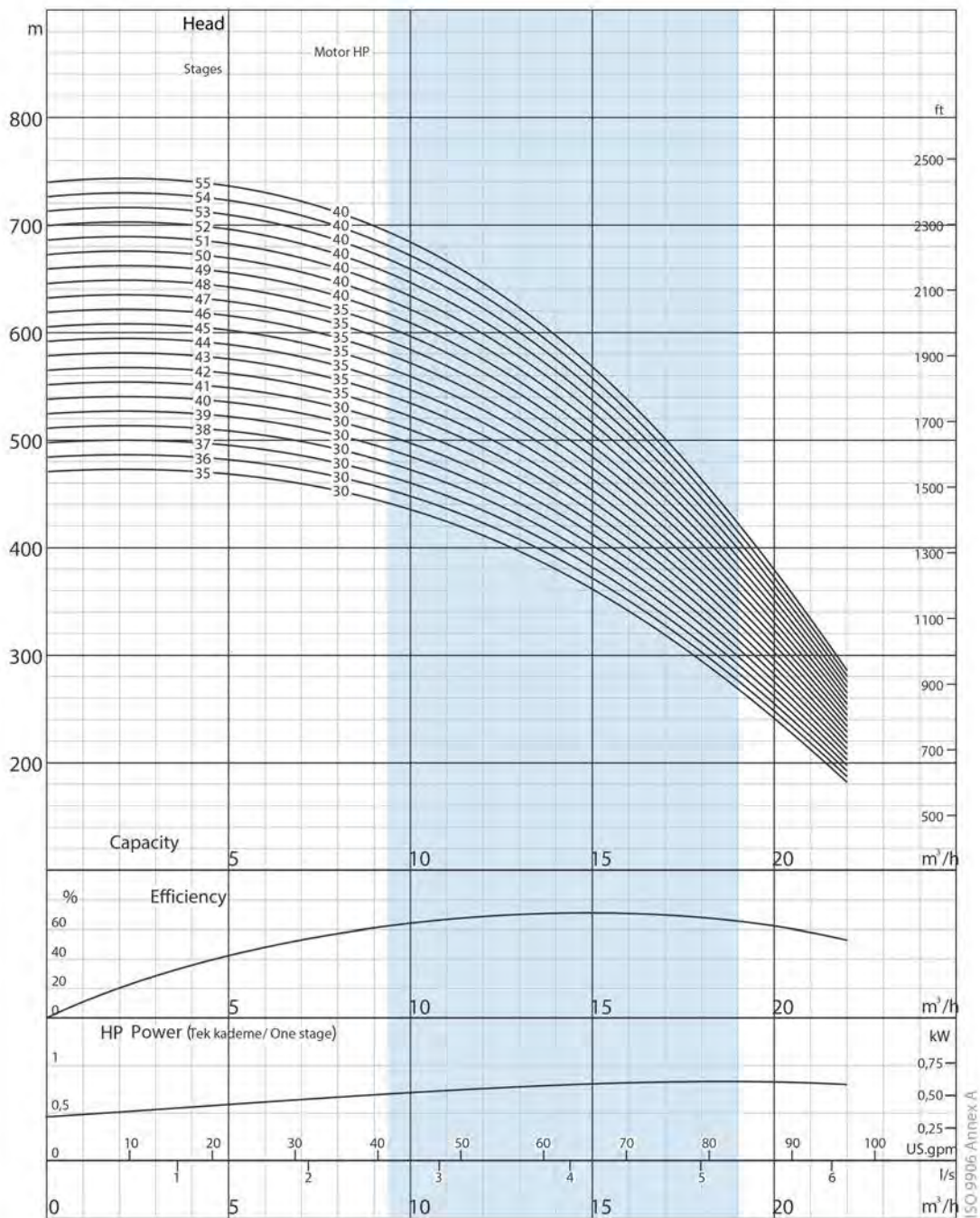

Due to continuous improvement in design we reserve the right to amend specifications or data without prior notice.

A6X 10 CR

No. of vanes
6

Outlet connection diameter
2 1/2" (inside threaded)

Pump outside diameter
132 mm

Rotation
CCW

Revolutions
3500 rpm

Shaft diameter
20 mm

The hydraulic working characteristics have been taken with water at 15 °C, at the atmospheric pressure of 1 bar and specific gravity is 1 gr/cm³.



Technical specifications

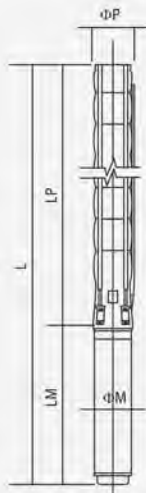

- Diffuser** : Stainless steel (AISI 304L)
- Impeller** : Stainless steel (AISI 304L)
- Pump shaft** : Stainless steel (AISI 420)
- Coupling** : Stainless steel (AISI 420)
- Strainer** : Stainless steel (AISI 304)
- Outlet connection diameter** : 2 1/2" (inside threaded)

- Max. sand content** : 50 gr / m³
- Valve cap** : Stainless steel
- Voltage** : 460 V (+%6 - %10)
- Frequency** : 60 Hz.
- Max. water temperature** : 30°C (50°C optional)
- Degree of protection** : IP 68



Pump type	Stages	Power		Dimensions (in)					Weight (lb)		
		kW	HP	L	LM	LP	ΦM	ΦP	Motor	Pump	Total
A6X 17 CR 05/04	4	4	5,5	46	26	20	6	5	88	22	110
A6X 17 CR 07/05	5	5,5	7,5	49	27	23	6	5	96	24	120
A6X 17 CR 07/06	6	5,5	7,5	52	27	25	6	5	96	29	125
A6X 17 CR 10/07	7	7,5	10	57	30	27	6	5	110	31	141
A6X 17 CR 10/08	8	7,5	10	59	30	30	6	5	110	35	146
A6X 17 CR 10/09	9	7,5	10	62	30	32	6	5	110	37	148
A6X 17 CR 10/10	10	7,5	10	66	31	34	6	5	121	40	161
A6X 17 CR 12/11	11	9,3	12,5	68	31	37	6	5	121	44	165
A6X 17 CR 15/12	12	11	15	73	34	39	6	5	132	46	179
A6X 17 CR 15/13	13	11	15	75	34	42	6	5	132	51	183
A6X 17 CR 17/14	14	13	17,5	80	36	44	6	5	143	53	196
A6X 17 CR 17/15	15	13	17,5	82	36	46	6	5	143	57	201

Pump type	Stages	Power		Current (A)	gal/h	Head (ft)									
		kW	HP			0	1585	3170	3963	4491	5019	5548	6076	7397	
A6X 17 CR 05/04	4	4	5,5	8,4		220	217	203	190	180	167	151	135	85	
A6X 17 CR 07/05	5	5,5	7,5	11,3		272	269	253	236	223	207	187	167	105	
A6X 17 CR 07/06	6	5,5	7,5	11,3		328	325	305	285	269	249	226	200	128	
A6X 17 CR 10/07	7	7,5	10	14,2		384	377	354	331	315	289	262	233	148	
A6X 17 CR 10/08	8	7,5	10	14,2		436	433	407	381	358	331	302	266	171	
A6X 17 CR 10/09	9	7,5	10	14,2		492	486	456	427	404	374	338	299	190	
A6X 17 CR 10/10	10	7,5	10	17,4		548	541	509	476	449	413	377	335	213	
A6X 17 CR 12/11	11	9,3	12,5	17,4		600	594	558	522	492	456	413	367	233	
A6X 17 CR 15/12	12	11	15	19,6		656	650	607	571	538	499	453	400	256	
A6X 17 CR 15/13	13	11	15	19,6		712	702	659	617	581	538	489	433	276	
A6X 17 CR 17/14	14	13	17,5	23,4		764	758	709	666	627	581	528	466	295	
A6X 17 CR 17/15	15	13	17,5	23,4		820	810	761	712	673	623	564	499	318	

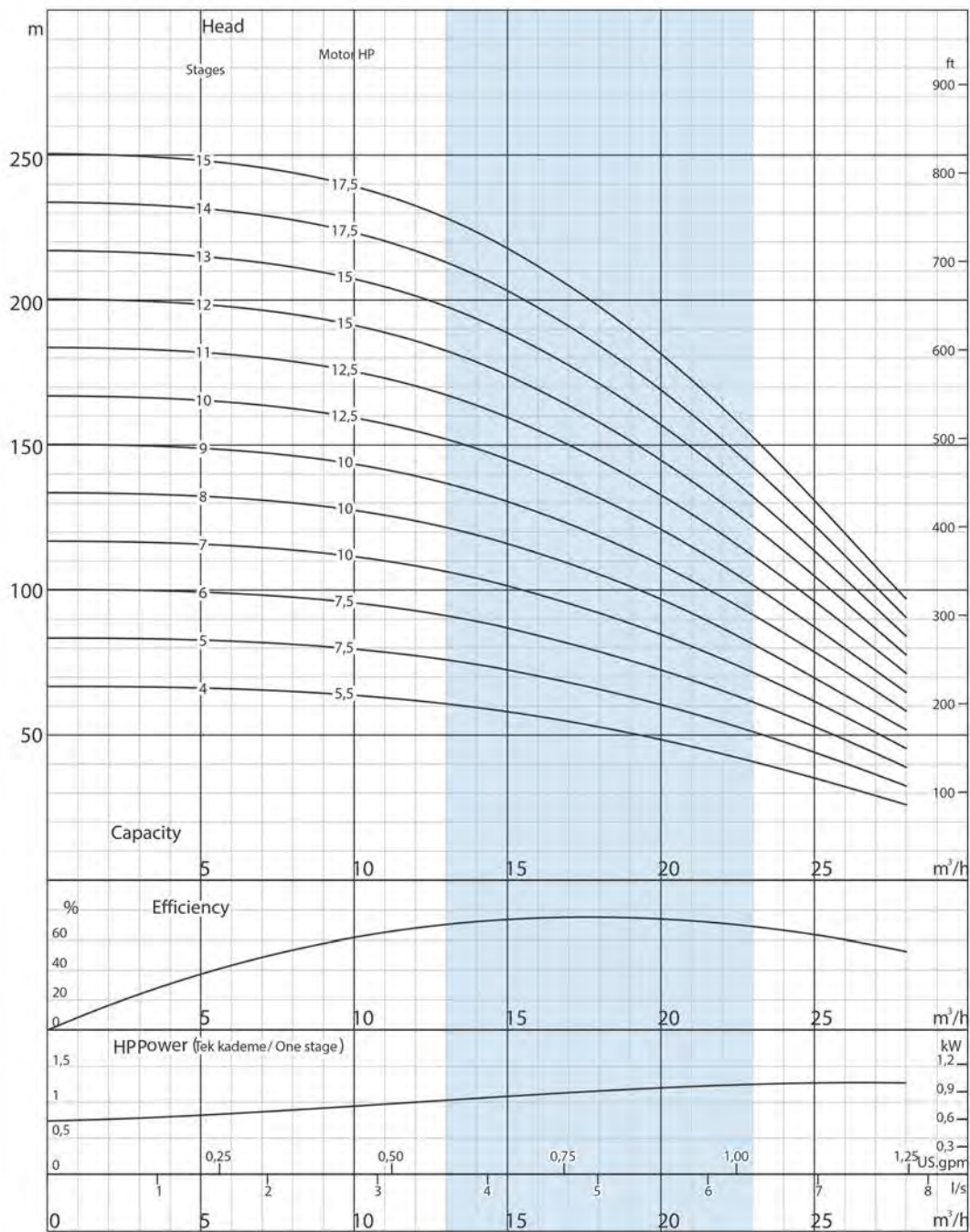

ISO 9906 Annex A

Due to continuous improvement in design we reserve the right to amend specifications or data without prior notice.

A6X 17 CR

No. of vanes
6

Outlet connection diameter
/ 2 1/2" (inside threaded)

Pump outside diameter
132 mm

Rotation
CCW

Revolution
3500 rpm

Shaft diameter
20 mm



The hydraulic working characteristics have been taken with water at 15 °C, at the atmospheric pressure of 1 bar and specific gravity is 1 gr/cm³

Technical specifications

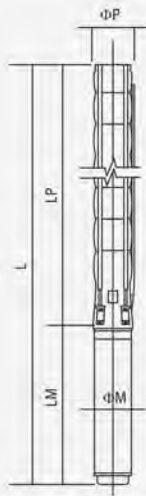

- Diffuser** : Stainless steel (AISI 304L)
- Impeller** : Stainless steel (AISI 304L)
- Pump shaft** : Stainless steel (AISI 420)
- Coupling** : Stainless steel (AISI 420)
- Strainer** : Stainless steel (AISI 304)
- Outlet connection diameter** : 2 1/2" (inside threaded)

- Max. sand content** : 50 gr / m³
- Valve cap** : Stainless steel
- Voltage** : 460 V (+%6 - %10)
- Frequency** : 60 Hz.
- Max. water temperature** : 30°C (50°C optional)
- Degree of protection** : IP 68



Pump type	Stages	Power		Dimensions (in)					Weight (lb)		
		kW	HP	L	LM	LP	ΦM	ΦP	Motor	Pump	Total
A6X 17 CR 20/16	16	15	20	87	38	49	6	5	159	60	218
A6X 17 CR 20/17	17	15	20	89	38	51	6	5	159	64	223
A6X 17 CR 20/18	18	15	20	92	38	53	6	5	159	66	225
A6X 17 CR 25/19	19	18,5	25	95	40	56	6	5	168	68	236
A6X 17 CR 25/20	20	18,5	25	98	40	58	6	5	168	73	240
A6X 17 CR 25/21	21	18,5	25	100	40	61	6	5	168	75	243
A6X 17 CR 25/22	22	18,5	25	103	40	63	6	5	168	79	247
A6X 17 CR 30/23	23	22	30	109 / 100	44 / 35	65	6 / 7	5	192 / 190	82	273 / 271
A6X 17 CR 30/24	24	22	30	111 / 103	44 / 35	68	6 / 7	5	192 / 190	86	278 / 276
A6X 17 CR 30/25	25	22	30	114 / 105	44 / 35	70	6 / 7	5	192 / 190	88	280 / 278
A6X 17 CR 30/26	26	22	30	116 / 108	44 / 35	73	6 / 7	5	192 / 190	93	284 / 282
A6X 17 CR 35/27	27	26,5	35	123 / 112	48 / 37	75	6 / 7	5	216 / 201	95	311 / 295
A6X 17 CR 35/28	28	26,5	35	125 / 114	48 / 37	77	6 / 7	5	216 / 201	99	315 / 300
A6X 17 CR 35/29	29	26,5	35	128 / 117	48 / 37	80	6 / 7	5	216 / 201	101	317 / 302
* A6X 17 CR 35/30	30	26,5	35	130 / 119	48 / 37	82	6 / 7	7	216 / 201	165	381 / 366
* A6X 17 CR 40/31	31	30	40	134 / 123 / 126	49 / 39 / 42	84	6 / 7 / 8	7	227 / 227 / 284	170	397 / 397 / 454

Pump type	Stages	Power		Current (A)	gal/h i/s	0	1585	3170	3963	4491	5019	5548	6076	7397
		kW	HP			0,00	1,67	3,33	4,17	4,72	5,28	5,83	6,39	7,78
A6X 17 CR 20/16	16	15	20	27,3	Head (ft)	876	863	810	761	715	663	600	531	338
A6X 17 CR 20/17	17	15	20	27,3		928	919	863	807	761	705	640	568	361
A6X 17 CR 20/18	18	15	20	27,3		984	971	912	856	807	745	676	600	381
A6X 17 CR 25/19	19	18,5	25	34,5		1040	1027	965	902	850	787	715	633	404
A6X 17 CR 25/20	20	18,5	25	34,5		1093	1079	1014	951	896	830	751	666	423
A6X 17 CR 25/21	21	18,5	25	34,5		1148	1135	1066	997	942	869	791	699	446
A6X 17 CR 25/22	22	18,5	25	34,5		1204	1188	1115	1047	984	912	827	732	466
A6X 17 CR 30/23	23	22	30	40,1		1260	1243	1165	1093	1030	955	866	768	489
A6X 17 CR 30/24	24	22	30	40,1		1312	1296	1217	1142	1076	994	902	801	509
A6X 17 CR 30/25	25	22	30	40,1		1368	1352	1266	1188	1119	1037	942	833	531
A6X 17 CR 30/26	26	22	30	40,1		1424	1404	1319	1237	1165	1079	978	866	551
A6X 17 CR 35/27	27	26,5	35	47,1		1476	1460	1368	1283	1211	1119	1017	899	571
A6X 17 CR 35/28	28	26,5	35	47,1		1532	1512	1421	1332	1253	1161	1053	932	594
A6X 17 CR 35/29	29	26,5	35	47,1		1588	1565	1470	1378	1299	1204	1093	968	614
* A6X 17 CR 35/30	30	26,5	35	47,1		1640	1621	1522	1427	1345	1243	1129	1001	636
* A6X 17 CR 40/31	31	30	40	51		1696	1673	1572	1473	1388	1286	1165	1033	656

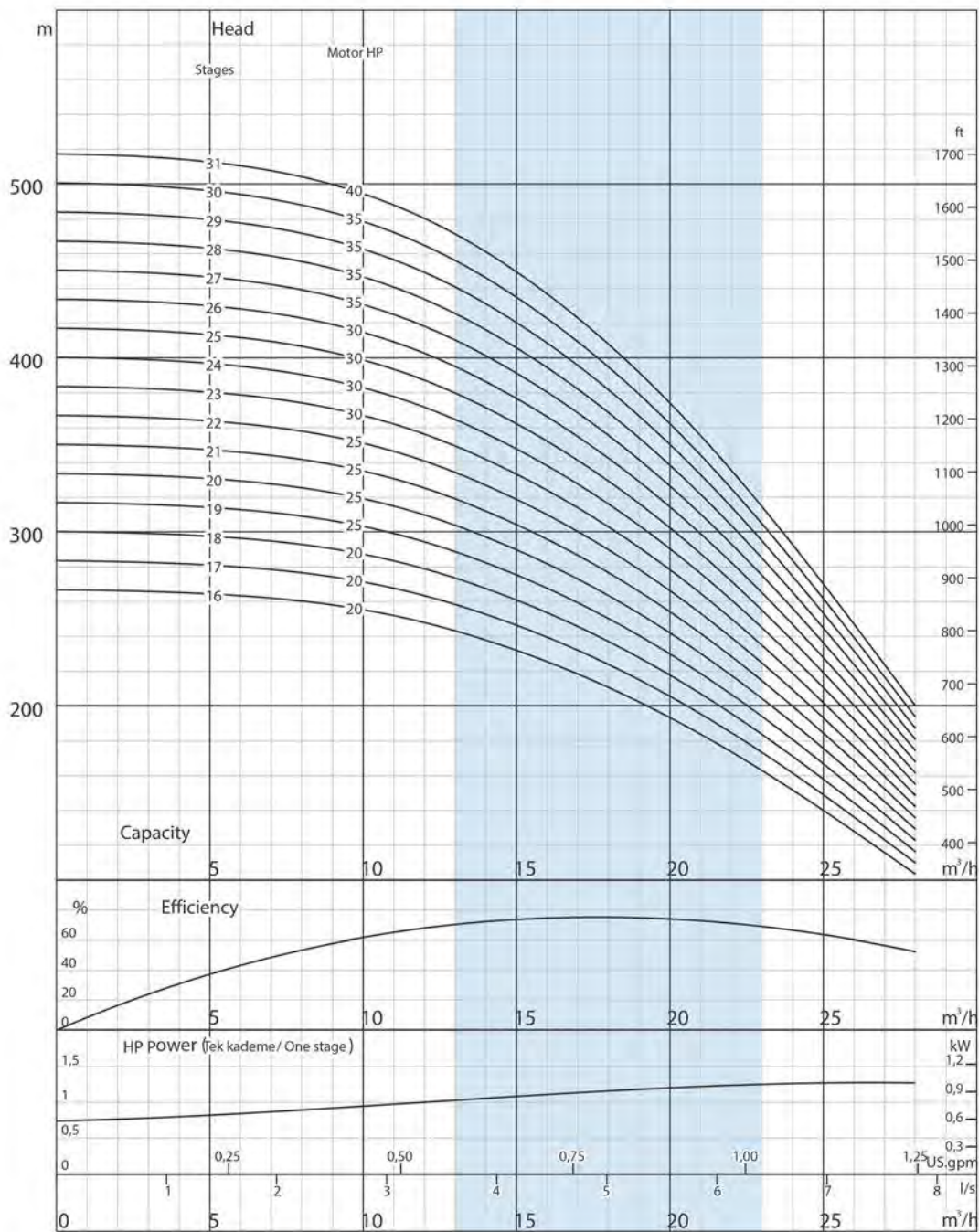

IS O 9906 Annex A

Due to continuous improvement in design we reserve the right to amend specifications or data without prior notice.

A6X 17 CR

No. of vanes
6

Outlet connection diameter
2 1/2" (inside threaded)

Pump outside diameter
132 mm

Rotation
CCW

Revolution
3500 rpm

Shaft diameter
20 mm

The hydraulic working characteristics have been taken with water at 15 °C, at the atmospheric pressure of 1 bar and specific gravity is 1 gr/cm³



Technical specifications

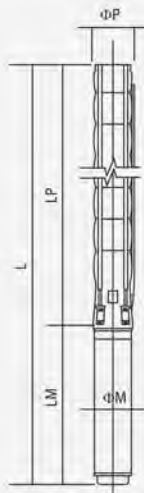

- Diffuser** : Stainless steel (AISI 304L)
- Impeller** : Stainless steel (AISI 304L)
- Pump shaft** : Stainless steel (AISI 420)
- Coupling** : Stainless steel (AISI 420)
- Strainer** : Stainless steel (AISI 304)
- Outlet connection diameter** : 2 1/2" (inside threaded)

- Max. sand content** : 50 gr / m³
- Valve cap** : Stainless steel
- Voltage** : 460 V (+%6 - %10)
- Frequency** : 60 Hz.
- Max. water temperature** : 30°C (50°C optional)
- Degree of protection** : IP 68



Pump type	Stages	Power		Dimensions (in)					Weight (lb)		
		kW	HP	L	LM	LP	ΦM	ΦP	Motor	Pump	Total
* A6X 17 CR 40/32	32	30	40	136/125/128	49/39/42	87	6/7/8	7	227/227/284	172	399/399/456
* A6X 17 CR 40/33	33	30	40	138/128/131	49/39/42	89	6/7/8	7	227/227/284	176	403/403/461
* A6X 17 CR 40/34	34	30	40	141/130/133	49/39/42	92	6/7/8	7	227/227/284	181	408/408/465
* A6X 17 CR 40/35	35	30	40	143/133/136	49/39/42	94	6/7/8	7	227/227/284	185	412/412/470
* A6X 17 CR 40/36	36	30	40	145/135/138	49/39/42	96	6/7/8	7	227/227/284	190	417/417/474
* A6X 17 CR 50/37	37	37	50	152/140/143	53/42/44	99	6/7/8	7	243/249/304	192	434/441/496
* A6X 17 CR 50/38	38	37	50	154/143/145	53/42/44	101	6/7/8	7	243/249/304	196	439/445/500
* A6X 17 CR 50/39	39	37	50	157/145/147	53/42/44	104	6/7/8	7	243/249/304	201	443/450/505
* A6X 17 CR 50/40	40	37	50	159/148/150	53/42/44	106	6/7/8	7	243/249/304	205	448/454/509
* A6X 17 CR 50/41	41	37	50	161/150/152	53/42/44	108	6/7/8	7	243/249/304	209	452/459/514
* A6X 17 CR 50/42	42	37	50	164/152/155	53/42/44	111	6/7/8	7	243/249/304	212	454/461/516
* A6X 17 CR 60/43	43	45	60	158/160	45/47	113	7/8	7	280/335	216	496/551
* A6X 17 CR 60/44	44	45	60	160/163	45/47	115	7/8	7	280/335	220	500/556
* A6X 17 CR 60/45	45	45	60	163/165	45/47	118	7/8	7	280/335	225	505/560
* A6X 17 CR 60/46	46	45	60	165/167	45/47	120	7/8	7	280/335	227	507/562
* A6X 17 CR 60/47	47	45	60	167/170	45/47	123	7/8	7	280/335	231	511/567
* A6X 17 CR 60/48	48	45	60	170/172	45/47	125	7/8	7	280/335	236	516/571
* A6X 17 CR 60/49	49	45	60	172/175	45/47	127	7/8	7	280/335	240	520/575
* A6X 17 CR 60/50	50	45	60	175/180	45/47	130	7/8	7	280/335	245	525/580

Pump type	Stages	Power		Current (A)	gal/h i/s	Head (ft)												
		kW	HP			0	1585	3170	3963	4491	5019	5548	6076	7397				
* A6X 17 CR 40/32	32	30	40	51	1752	1729	1624	1522	1434	1325	1204	1066	679					
* A6X 17 CR 40/33	33	30	40	51	1804	1781	1673	1568	1480	1368	1240	1099	699					
* A6X 17 CR 40/34	34	30	40	51	1860	1837	1722	1617	1522	1411	1280	1132	722					
* A6X 17 CR 40/35	35	30	40	51	1916	1890	1775	1663	1568	1450	1316	1165	741					
* A6X 17 CR 40/36	36	30	40	51	1969	1946	1824	1713	1614	1493	1355	1201	764					
* A6X 17 CR 50/37	37	37	50	61,4	2024	1998	1877	1759	1657	1535	1391	1234	784					
* A6X 17 CR 50/38	38	37	50	61,4	2080	2054	1926	1808	1703	1575	1430	1266	804					
* A6X 17 CR 50/39	39	37	50	61,4	2133	2106	1978	1854	1745	1617	1467	1299	827					
* A6X 17 CR 50/40	40	37	50	61,4	2188	2162	2028	1903	1791	1660	1506	1332	846					
* A6X 17 CR 50/41	41	37	50	61,4	2244	2215	2080	1949	1837	1699	1542	1365	869					
* A6X 17 CR 50/42	42	37	50	61,4	2297	2270	2129	1998	1880	1742	1581	1401	889					
* A6X 17 CR 60/43	43	45	60	74,8	2352	2323	2182	2044	1926	1781	1617	1434	912					
* A6X 17 CR 60/44	44	45	60	74,8	2408	2375	2231	2093	1972	1824	1657	1467	932					
* A6X 17 CR 60/45	45	45	60	74,8	2461	2431	2283	2139	2014	1867	1693	1499	955					
* A6X 17 CR 60/46	46	45	60	74,8	2516	2484	2333	2188	2060	1906	1729	1532	974					
* A6X 17 CR 60/47	47	45	60	74,8	2572	2539	2382	2234	2106	1949	1768	1565	997					
* A6X 17 CR 60/48	48	45	60	74,8	2625	2592	2434	2283	2149	1991	1804	1598	1017					
* A6X 17 CR 60/49	49	45	60	74,8	2680	2648	2484	2329	2195	2031	1844	1634	1040					
* A6X 17 CR 60/50	50	45	60	74,8	2736	2700	2536	2379	2241	2073	1880	1667	1060					

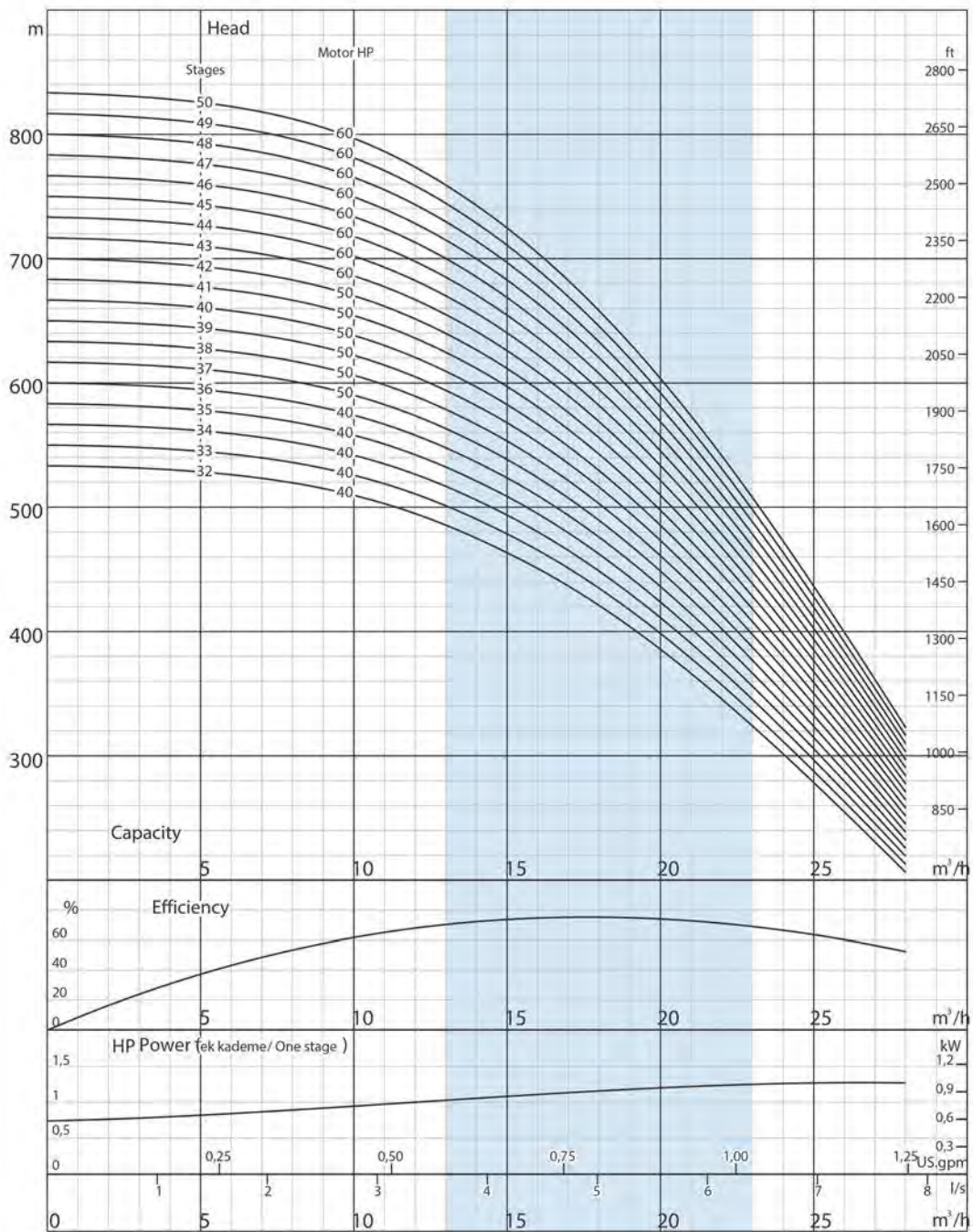

ISO 9906 Annex A

Due to continuous improvement in design we reserve the right to amend specifications or data without prior notice.

A6X 17 CR

No. of vanes
6

Outlet connection diameter
2 1/2" (inside threaded)

Pump outside diameter
132 mm

Rotation
CCW

Revolutions
3500 rpm

Shaft diameter
20 mm

The hydraulic working characteristics have been taken with water at 15 C, at the atmospheric pressure of 1 bar and specific gravity is 1 gr/cm



Technical specifications

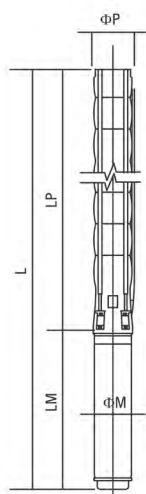

- Diffuser** : Stainless steel (AISI 304L)
- Impeller** : Stainless steel (AISI 304L)
- Pump shaft** : Stainless steel (AISI 420)
- Coupling** : Stainless steel (AISI 420)
- Strainer** : Stainless steel (AISI 304)
- Outlet connection diameter** : 3" (inside threaded)

- Max. sand content** : 50 gr / m³
- Valve cap** : Stainless steel
- Voltage** : 460 V (+%6 / -%10)
- Frequency** : 60 Hz.
- Max. water temperature** : 30°C (50°C optional)
- Degree of protection** : IP 68



Pump type	Stages	Power		Dimensions (in)					Weight (lb)		
		kW	HP	L	LM	LP	ΦM	ΦP	Motor	Pump	Total
A6X 30 CR 05/03	3	4	5,5	47	26	22	6	5	88	24	112
A6X 30 CR 07/04	4	5,5	7,5	52	27	26	6	5	96	29	125
A6X 30 CR 10/05	5	7,5	10	59	30	29	6	5	110	33	143
A6X 30 CR 12/06	6	9,3	12,5	65	31	33	6	5	121	37	159
A6X 30 CR 12/07	7	9,3	12,5	68	31	37	6	5	121	42	163
A6X 30 CR 15/08	8	11	15	74	34	41	6	5	132	46	179
A6X 30 CR 17/09	9	13	17,5	80	36	44	6	5	143	51	194
A6X 30 CR 17/10	10	13	17,5	84	36	48	6	5	143	55	198
A6X 30 CR 20/11	11	15	20	90	38	52	6	5	159	60	218
A6X 30 CR 25/12	12	18,5	25	95	40	55	6	5	168	64	231
A6X 30 CR 25/13	13	18,5	25	99	40	59	6	5	168	68	236
A6X 30 CR 25/14	14	18,5	25	103	40	63	6	5	168	73	240
A6X 30 CR 30/15	15	22	30	110 / 102	44 / 35	67	6 / 7	5	3 / 3	79	5 / 5
A6X 30 CR 30/16	16	22	30	114 / 105	44 / 35	70	6 / 7	5	3 / 3	84	5 / 5
A6X 30 CR 30/17	17	22	30	118 / 109	44 / 35	74	6 / 7	5	3 / 3	88	5 / 5

Pump type	Stages	Power		Current (A)	gal/h l/s	Head (ft)													
		kW	HP			0	3170	5283	6340	7397	8454	9510	10567	11888					
A6X 30 CR 05/03	3	4	5,5	8,4	171	161	148	138	128	118	105	89	69						
A6X 30 CR 07/04	4	5,5	7,5	11,3	226	213	197	184	171	157	141	121	92						
A6X 30 CR 10/05	5	7,5	10	14,2	282	266	246	230	213	197	174	151	115						
A6X 30 CR 12/06	6	9,3	12,5	17,4	338	322	295	276	256	236	210	180	138						
A6X 30 CR 12/07	7	9,3	12,5	17,4	394	374	344	325	302	276	243	210	161						
A6X 30 CR 15/08	8	11	15	19,6	453	427	390	371	344	315	279	240	184						
A6X 30 CR 17/09	9	13	17,5	23,4	509	479	440	417	387	351	315	269	207						
A6X 30 CR 17/10	10	13	17,5	23,4	564	535	489	463	430	390	348	302	230						
A6X 30 CR 20/11	11	15	20	27,3	620	587	538	509	472	430	384	331	253						
A6X 30 CR 25/12	12	18,5	25	34,5	676	640	587	554	515	469	420	361	276						
A6X 30 CR 25/13	13	18,5	25	34,5	735	692	636	600	558	509	453	390	302						
A6X 30 CR 25/14	14	18,5	25	34,5	791	748	686	646	600	548	489	420	325						
A6X 30 CR 30/15	15	22	30	40,1	846	801	735	692	643	587	525	449	348						
A6X 30 CR 30/16	16	22	30	40,1	902	853	784	738	686	627	558	482	371						
A6X 30 CR 30/17	17	22	30	40,1	958	906	833	784	728	666	594	512	394						

Performance Table

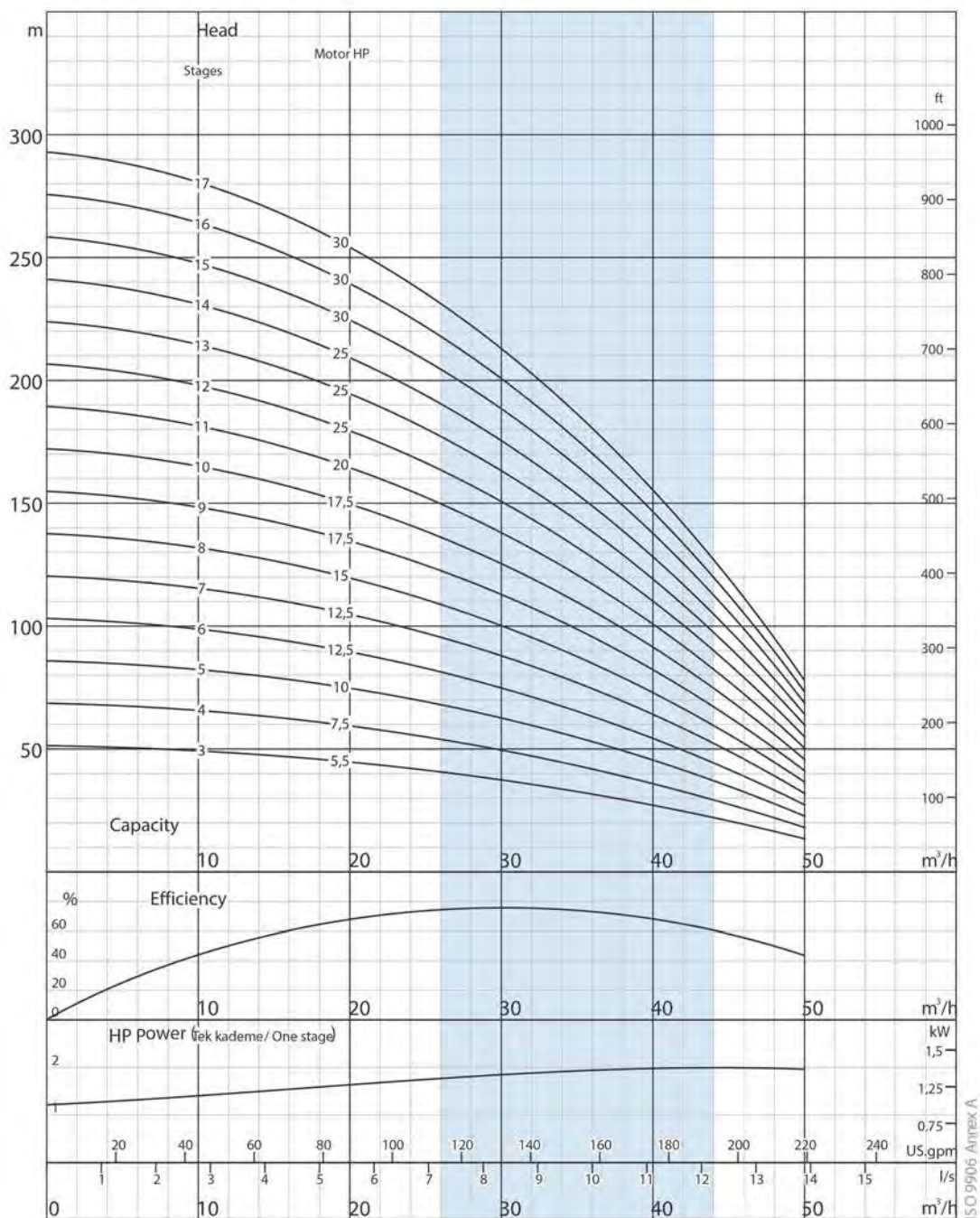

IS 0 9906 Annex A

Due to continuous improvement in design we reserve the right to amend specifications or data without prior notice.

A6X 30 CR

No. of vanes
7

Outlet connection diameter
3" (inside threaded)

Pump outside diameter
132 mm

Rotation
CCW

Revolution
3500 rpm

Shaft diameter
22 mm

The hydraulic working characteristics have been taken with water at 15 °C, at the atmospheric pressure of 1 bar and specific gravity is 1 gr/cm³.



Technical specifications

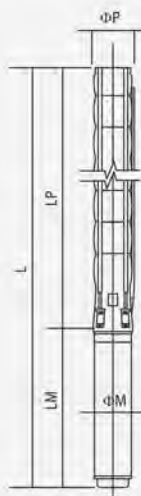

- Diffuser** : Stainless steel (AISI 304L)
- Impeller** : Stainless steel (AISI 304L)
- Pump shaft** : Stainless steel (AISI 420)
- Coupling** : Stainless steel (AISI 420)
- Strainer** : Stainless steel (AISI 304)
- Outlet connection diameter** : 3" (inside threaded)

- Max. sand content** : 50 gr / m³
- Valve cap** : Stainless steel
- Voltage** : 460 V (+%6 - %10)
- Frequency** : 60 Hz.
- Max. water temperature** : 30°C (50°C optional)
- Degree of protection** : IP 68



Pump type	Stages	Power		Dimensions (in)					Weight (lb)		
		kW	HP	L	LM	LP	ΦM	ΦP	Motor	Pump	Total
A6X 30 CR 35/18	18	26,5	35	126/115	48/37	78	6/7	5	216/201	93	309/293
A6X 30 CR 35/19	19	26,5	35	130/119	48/37	82	6/7	5	216/201	97	313/298
A6X 30 CR 35/20	20	26,5	35	133/122	48/37	85	6/7	5	216/201	101	317/302
A6X 30 CR 40/21	21	30	40	138/128/131	49/39/42	89	6/7/8	5	227/227/284	106	333/333/390
A6X 30 CR 40/22	22	30	40	142/131/134	49/39/42	93	6/7/8	5	227/227/284	110	337/337/395
A6X 30 CR 40/23	23	30	40	146/135/138	49/39/42	97	6/7/8	5	227/227/284	115	342/342/399
A6X 30 CR 50/24	24	37	50	153/142/144	53/42/44	100	6/7/8	5	243/249/304	119	362/362/423
A6X 30 CR 50/25	25	37	50	157/146/148	53/42/44	104	6/7/8	5	243/249/304	123	366/373/428
A6X 30 CR 50/26	26	37	50	161/150/152	53/42/44	108	6/7/8	5	243/249/304	128	370/377/432
A6X 30 CR 50/27	27	37	50	165/153/156	53/42/44	112	6/7/8	5	243/249/304	132	375/381/437
A6X 30 CR 50/28	28	37	50	168/157/159	53/42/44	115	6/7/8	5	243/249/304	139	381/388/443
A6X 30 CR 60/29	29	45	60	164/166	45/47	119	7/8	7	280/335	214	494/549
A6X 30 CR 60/30	30	45	60	168/170	45/47	123	7/8	7	280/335	220	500/556
A6X 30 CR 60/31	31	45	60	171/174	45/47	127	7/8	7	280/335	227	507/562
A6X 30 CR 60/32	32	45	60	175/178	45/47	130	7/8	7	280/335	231	511/567
A6X 30 CR 60/33	33	45	60	179/181	45/47	134	7/8	7	280/335	238	518/573
A6X 30 CR 75/34	34	55	75	188	51	138	8	7	375	245	619
A6X 30 CR 75/35	35	55	75	192	51	141	8	7	375	249	624
A6X 30 CR 75/36	36	55	75	196	51	145	8	7	375	256	631
A6X 30 CR 75/37	37	55	75	200	51	149	8	7	375	260	635
A6X 30 CR 75/38	38	55	75	203	51	153	8	7	375	267	642
A6X 30 CR 75/39	39	55	75	207	51	156	8	7	375	273	648

Pump type	Stages	Power		Current (A)	gal/h	Head (ft)												
		kW	HP			0	3170	5283	6340	7397	8454	9510	10567	11888				
						0,00	3,33	5,56	6,67	7,78	8,89	10,00	11,11	12,50				
A6X 30 CR 35/18	18	26,5	35	47		1017	961	883	830	771	705	627	541	417				
A6X 30 CR 35/19	19	26,5	35	47		1073	1014	932	876	817	745	663	571	440				
A6X 30 CR 35/20	20	26,5	35	47		1129	1066	981	925	860	784	699	600	463				
A6X 30 CR 40/21	21	30	40	51		1184	1119	1030	971	902	823	732	630	486				
A6X 30 CR 40/22	22	30	40	51		1240	1175	1079	1017	945	863	768	663	509				
A6X 30 CR 40/23	23	30	40	51		1299	1227	1129	1063	988	902	804	692	531				
A6X 30 CR 50/24	24	37	50	61,4		1355	1280	1175	1109	1030	942	837	722	554				
A6X 30 CR 50/25	25	37	50	61,4		1411	1332	1224	1155	1073	978	873	751	577				
A6X 30 CR 50/26	26	37	50	61,4		1467	1388	1273	1201	1115	1017	909	781	600				
A6X 30 CR 50/27	27	37	50	61,4		1522	1440	1322	1247	1158	1056	942	810	623				
A6X 30 CR 50/28	28	37	50	61,4		1581	1493	1371	1293	1201	1096	978	840	646				
A6X 30 CR 60/29	29	45	60	74,8		1637	1545	1421	1339	1243	1135	1010	873	669				
A6X 30 CR 60/30	30	45	60	74,8		1693	1601	1470	1385	1286	1175	1047	902	692				
A6X 30 CR 60/31	31	45	60	74,8		1749	1654	1519	1430	1332	1214	1083	932	715				
A6X 30 CR 60/32	32	45	60	74,8		1804	1706	1568	1480	1375	1253	1115	961	738				
A6X 30 CR 60/33	33	45	60	74,8		1864	1759	1617	1526	1417	1293	1152	991	761				
A6X 30 CR 75/34	34	55	75	90,2		1919	1814	1667	1572	1460	1332	1188	1020	784				
A6X 30 CR 75/35	35	55	75	90,2		1975	1867	1716	1617	1503	1371	1220	1053	807				
A6X 30 CR 75/36	36	55	75	90,2		2031	1919	1765	1663	1545	1411	1257	1083	830				
A6X 30 CR 75/37	37	55	75	90,2		2087	1972	1814	1709	1588	1450	1293	1112	853				
A6X 30 CR 75/38	38	55	75	90,2		2146	2028	1864	1755	1631	1490	1325	1142	876				
A6X 30 CR 75/39	39	55	75	90,2		2201	2080	1909	1801	1673	1529	1362	1171	902				

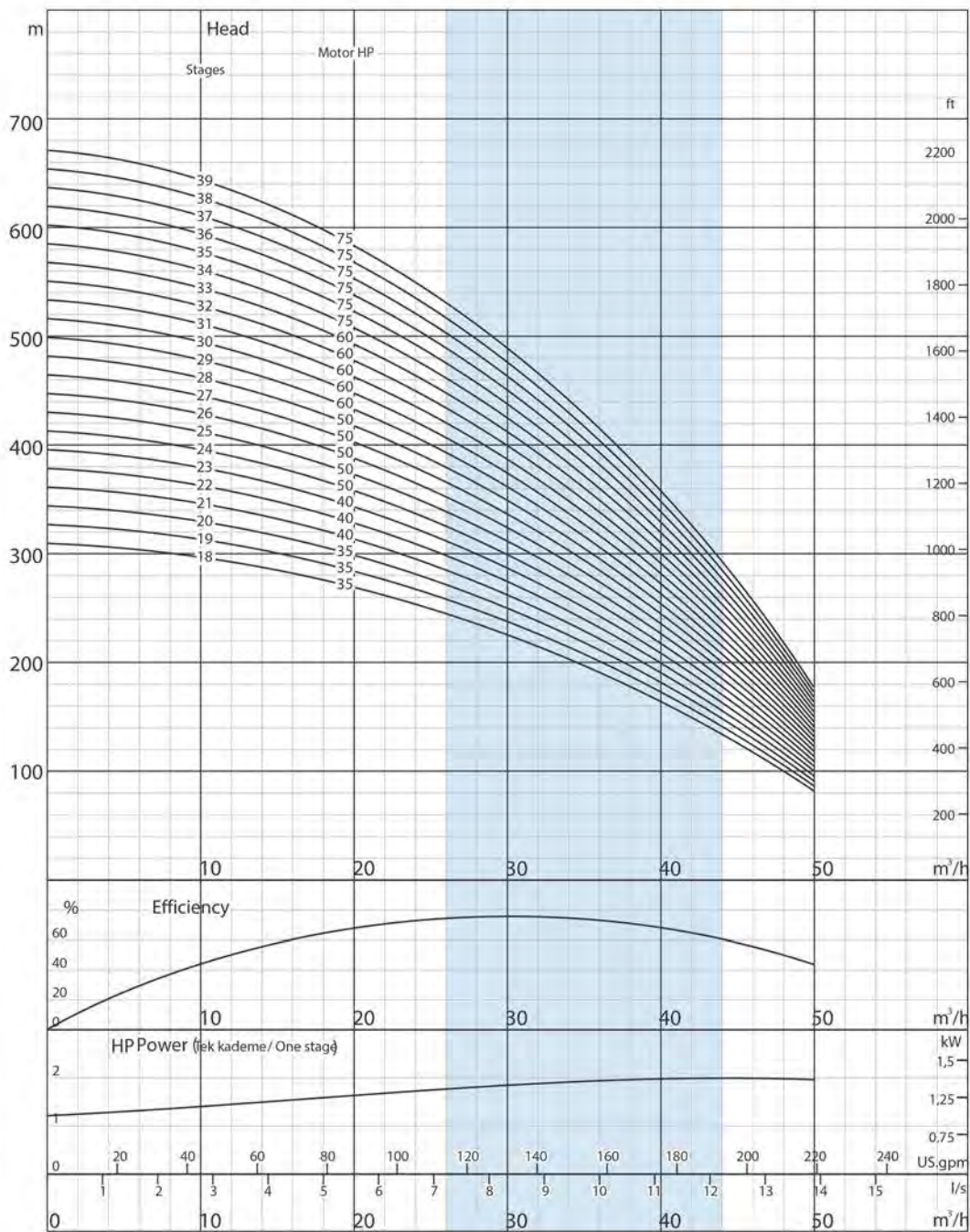

IS 0 9906 Annex A

Due to continuous improvement in design we reserve the right to amend specifications or data without prior notice.

A6X 30 CR

No. of vanes
7

Outlet connection diameter
3" (inside threaded)

Pump outside diameter
132 mm

Rotation
CCW

Revolution
3500 rpm

Shaft diameter
22 mm

The hydraulic working characteristics have been taken with water at 15 °C, at the atmospheric pressure of 1 bar and specific gravity is 1 gr/cm³



Technical specifications

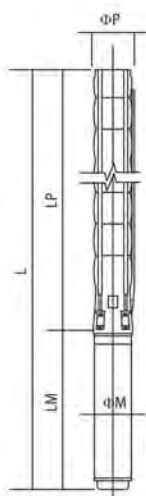

- Diffuser** : Stainless steel (AISI 304L)
- Impeller** : Stainless steel (AISI 304L)
- Pump shaft** : Stainless steel (AISI 420)
- Coupling** : Stainless steel (AISI 420)
- Strainer** : Stainless steel (AISI 304)
- Outlet connection diameter** : 4" (inside threaded)

- Max. sand content** : 50 gr / m³
- Valve cap** : Stainless steel
- Voltage** : 460 V (+%6 / -%10)
- Frequency** : 60 Hz.
- Max. water temperature** : 30°C (50°C optional)
- Degree of protection** : IP 68



Pump type	Stages	Power		Dimensions (in)					Weight (lb)		
		kW	HP	L	LM	LP	ΦM	ΦP	Motor	Pump	Total
A6X 46 CR 05/01	1	4	5,5	41	26	15	6	5	88	15	104
A6X 46 CR 07/02	2	5,5	7,5	46	27	19	6	5	96	22	118
A6X 46 CR 10/03	3	7,5	10	54	30	24	6	5	110	26	137
A6X 46 CR 12/04	4	9,3	12,5	60	31	28	6	5	121	33	154
A6X 46 CR 17/05	5	13	17,5	69	36	33	6	5	143	40	183
A6X 46 CR 20/06	6	15	20	75	38	37	6	5	159	44	203
A6X 46 CR 25/07	7	18,5	25	81	40	41	6	5	168	51	218
A6X 46 CR 25/08	8	18,5	25	86	40	46	6	5	168	57	225
A6X 46 CR 30/09	9	22	30	94 / 85	44 / 35	50	6 / 7	5	192 / 190	62	254 / 251
A6X 46 CR 35/10	10	26,5	35	103 / 92	48 / 37	55	6 / 7	5	216 / 201	68	284 / 269
A6X 46 CR 35/11	11	26,5	35	107 / 96	48 / 37	59	6 / 7	5	216 / 201	75	291 / 276

Pump type	Stages	Power		Current (A)	gal/h i/s	Head (ft)									
		kW	HP			0	5283	9246	10567	11888	13209	14529	15850	17171	
A6X 46 CR 05/01	1	4	5,5	8,4	69	66	56	52	49	46	43	39	36		
A6X 46 CR 07/02	2	5,5	7,5	11,3	141	131	112	105	98	92	85	79	69		
A6X 46 CR 10/03	3	7,5	10	14,2	210	197	167	157	148	138	128	115	105		
A6X 46 CR 12/04	4	9,3	12,5	17,4	282	262	223	210	197	184	167	154	141		
A6X 46 CR 17/05	5	13	17,5	23,4	351	325	279	262	243	226	210	194	174		
A6X 46 CR 20/06	6	15	20	27,3	423	390	335	312	292	272	253	233	210		
A6X 46 CR 25/07	7	18,5	25	34,5	492	456	390	364	341	318	295	272	243		
A6X 46 CR 25/08	8	18,5	25	34,5	561	522	446	417	390	364	338	308	279		
A6X 46 CR 30/09	9	22	30	40,1	633	587	499	469	440	410	381	348	315		
A6X 46 CR 35/10	10	26,5	35	47,1	702	653	554	522	489	456	423	387	348		
A6X 46 CR 35/11	11	26,5	35	47,1	774	719	610	574	538	502	466	427	384		

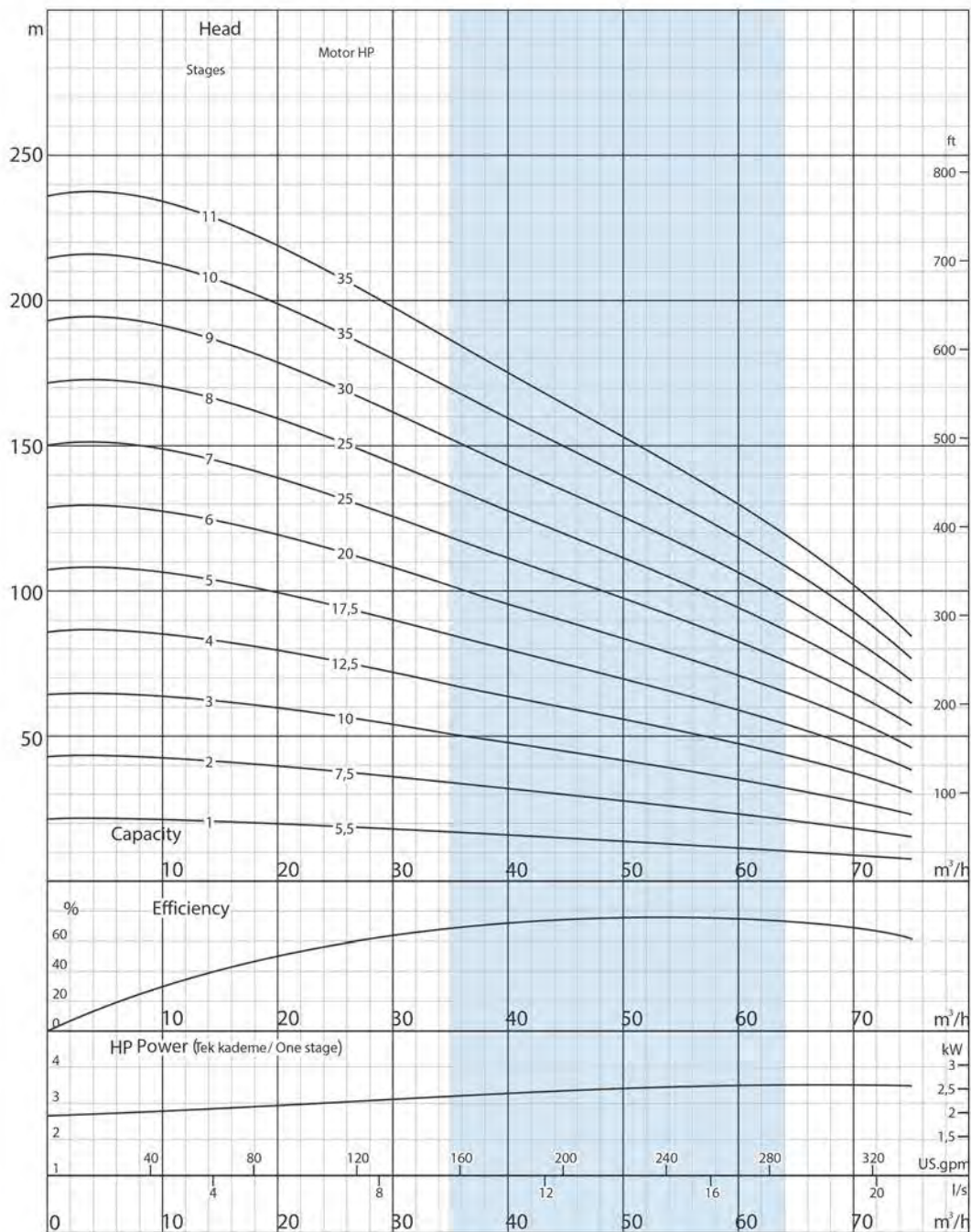

ISO 9906 Annex A

Due to continuous improvement in design we reserve the right to amend specifications or data without prior notice.

A6X 46 CR

No. of vanes
6

Outlet connection diameter
4" (inside threaded)

Pump outside diameter
144 mm

Rotation
CCW

Revolution
3500 rpm

Shaft diameter
22 mm



The hydraulic working characteristics have been taken with water at 15 °C, at the atmospheric pressure of 1 bar and specific gravity is 1 gr/cm³

Technical specifications

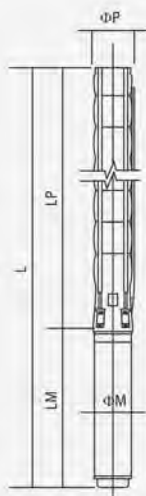

- Diffuser** : Stainless steel (AISI 304L)
- Impeller** : Stainless steel (AISI 304L)
- Pump shaft** : Stainless steel (AISI 420)
- Coupling** : Stainless steel (AISI 420)
- Strainer** : Stainless steel (AISI 304)
- Outlet connection diameter** : 4" (inside threaded)

- Max. sand content** : 50 gr / m³
- Valve cap** : Stainless steel
- Voltage** : 460 V (+%6 / -%10)
- Frequency** : 60 Hz.
- Max. water temperature** : 30°C (50°C optional)
- Degree of protection** : IP 68



Pump type	Stages	Power		Dimensions (in)					Weight (lb)		
		kW	HP	L	LM	LP	ΦM	ΦP	Motor	Pump	Total
A6X 46 CR 40/12	12	30	40	113 / 102 / 105	49 / 39 / 42	64	6 / 7 / 8	5	227 / 227 / 284	79	306 / 306 / 364
A6X 46 CR 40/13	13	30	40	117 / 107 / 110	49 / 39 / 42	68	6 / 7 / 8	5	227 / 227 / 284	86	313 / 313 / 370
A6X 46 CR 50/14	14	37	50	125 / 114 / 116	53 / 42 / 44	72	6 / 7 / 8	5	243 / 249 / 304	93	335 / 342 / 397
A6X 46 CR 50/15	15	37	50	130 / 119 / 121	53 / 42 / 44	77	6 / 7 / 8	5	243 / 249 / 304	97	340 / 346 / 401
A6X 46 CR 50/16	16	37	50	134 / 123 / 125	53 / 42 / 44	81	6 / 7 / 8	5	243 / 249 / 304	104	346 / 353 / 408
A6X 46 CR 60/17	17	45	60	130 / 133	45 / 47	86	7 / 8	5	280 / 335	108	388 / 443
A6X 46 CR 60/18	18	45	60	135 / 137	45 / 47	90	7 / 8	5	280 / 335	115	395 / 450
A6X 46 CR 60/19	19	45	60	139 / 142	45 / 47	94	7 / 8	5	280 / 335	121	401 / 456
A6X 46 CR 70/20	20	52	70	147 / 149	48 / 51	99	7 / 8	5	304 / 375	126	430 / 500
A6X 46 CR 75/21	21	55	75	154	51	103	8	5	375	132	507
A6X 46 CR 75/22	22	55	75	158	51	108	8	5	375	139	514
A6X 46 CR 75/23	23	55	75	163	51	112	8	5	375	143	518
A6X 46 CR 75/24	24	55	75	167	51	116	8	5	375	150	525

Pump type	Stages	Power		Current (A)	gal/h l/s	Head (ft)									
		kW	HP			0	5283	9246	10567	11888	13209	14530	15850	17171	
A6X 46 CR 40/12	12	30	40	51	Head (ft)	843	784	666	627	587	548	505	466	420	
A6X 46 CR 40/13	13	30	40	51		915	850	722	679	636	594	548	502	453	
A6X 46 CR 50/14	14	37	50	61,4		984	915	778	732	686	636	591	541	489	
A6X 46 CR 50/15	15	37	50	61,4		1053	978	833	784	732	682	633	581	522	
A6X 46 CR 50/16	16	37	50	61,4		1125	1043	889	837	781	728	676	620	558	
A6X 46 CR 60/17	17	45	60	74,8		1194	1109	945	889	830	774	719	659	594	
A6X 46 CR 60/18	18	45	60	74,8		1266	1175	1001	938	879	820	761	696	627	
A6X 46 CR 60/19	19	45	60	74,8		1335	1240	1056	991	928	866	804	735	663	
A6X 46 CR 70/20	20	52	70	85,3		1407	1306	1112	1043	978	912	843	774	699	
A6X 46 CR 75/21	21	55	75	90,2		1476	1371	1168	1096	1027	958	886	814	732	
A6X 46 CR 75/22	22	55	75	90,2		1549	1437	1224	1148	1076	1004	928	853	768	
A6X 46 CR 75/23	23	55	75	90,2		1617	1503	1280	1201	1125	1050	971	889	801	
A6X 46 CR 75/24	24	55	75	90,2		1686	1565	1335	1253	1175	1093	1014	928	837	

Performance Table

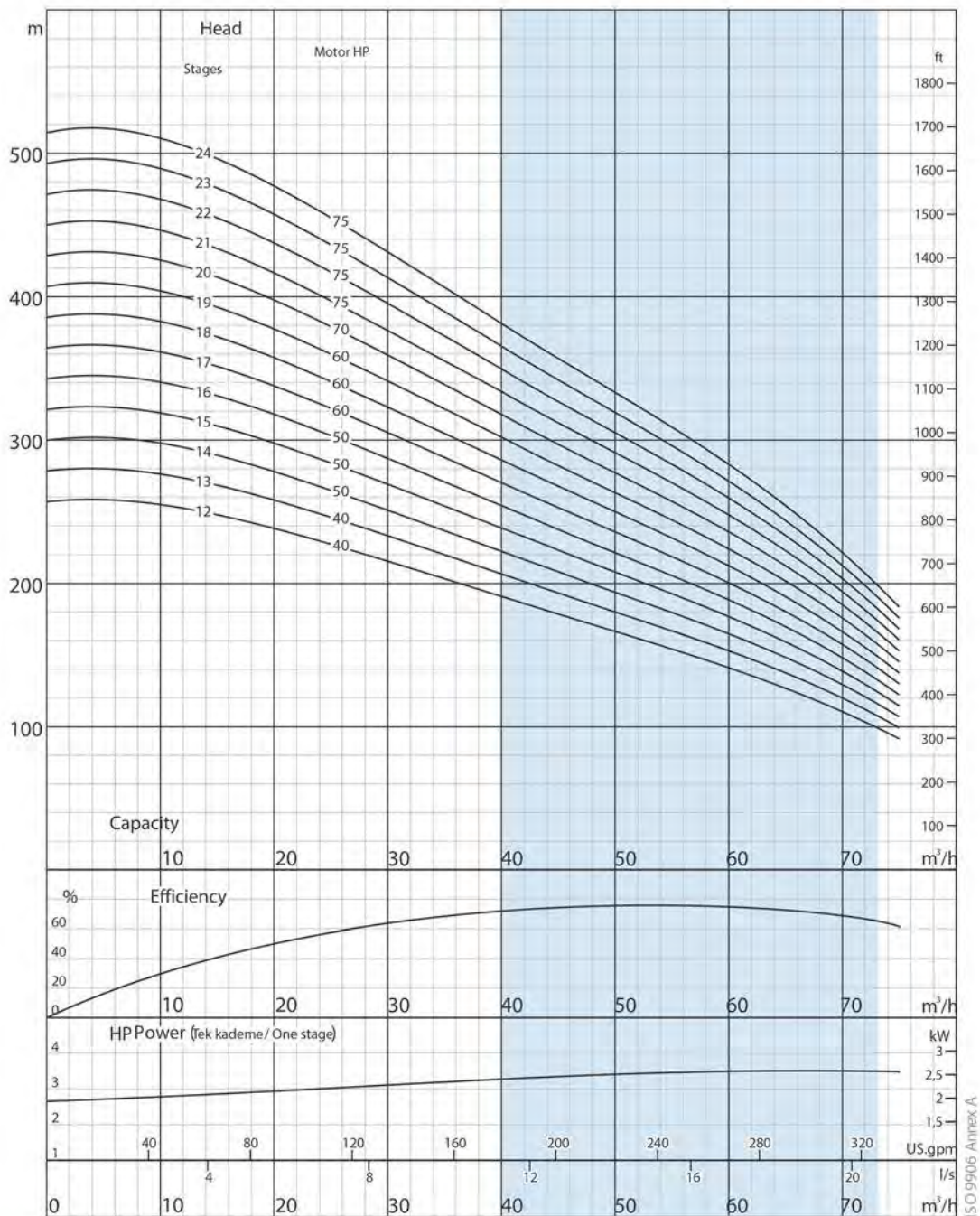

IS O 9906 Annex A

Due to continuous improvement in design we reserve the right to amend specifications or data without prior notice.

A6X 46 CR

No. of vanes
6

Outlet connection diameter
4" (inside threaded)

Pump outside diameter
144 mm

Rotation
CCW

Revolution
3500 rpm

Shaft diameter
22 mm



The hydraulic working characteristics have been taken with water at 15 °C, at the atmospheric pressure of 1 bar and specific gravity is 1 gr/cm³

Technical specifications

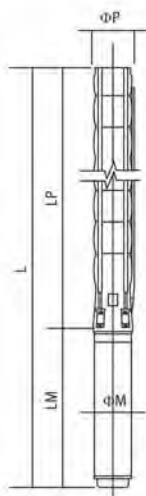

- Diffuser** : Stainless steel (AISI 304L)
- Impeller** : Stainless steel (AISI 304L)
- Pump shaft** : Stainless steel (AISI 420)
- Coupling** : Stainless steel (AISI 420)
- Strainer** : Stainless steel (AISI 304)
- Outlet connection diameter** : 4" (inside threaded)

- Max. sand content** : 50 gr / m³
- Valve cap** : Stainless steel
- Voltage** : 460 V (+%6 / -%10)
- Frequency** : 60 Hz.
- Max. water temperature** : 30°C (50°C optional)
- Degree of protection** : IP 68



Pump type	Stages	Power		Dimensions (in)					Weight (lb)		
		kW	HP	L	LM	LP	ΦM	ΦP	Motor	Pump	Total
A6X 60 CR 05/01	1	4	5,5	41	26	15	6	5	88	15	104
A6X 60 CR 07/02	2	5,5	7,5	46	27	19	6	5	96	22	118
A6X 60 CR 12/03	3	9,3	12,5	55	31	24	6	5	121	26	148
A6X 60 CR 15/04	4	11	15	62	34	28	6	5	132	33	165
A6X 60 CR 20/03	3	15	20	71	38	33	6	5	159	40	198
A6X 60 CR 25/06	6	18,5	25	77	40	37	6	5	168	44	212
A6X 60 CR 30/07	7	22	30	85 / 77	44 / 35	41	6 / 7	5	192 / 190	51	243 / 240
A6X 60 CR 30/08	8	22	30	89 / 81	44 / 35	46	6 / 7	5	192 / 190	57	249 / 247
A6X 60 CR 35/09	9	26,5	35	98 / 87	48 / 37	50	6 / 7	5	216 / 201	62	278 / 262
A6X 60 CR 40/10	10	30	40	104 / 93 / 96	49 / 39 / 42	55	6 / 7 / 8	5	228 / 228 / 284	68	295 / 295 / 353
A6X 60 CR 40/11	11	30	40	108 / 98 / 101	49 / 39 / 42	59	6 / 7 / 8	5	228 / 228 / 284	75	302 / 302 / 359

Pump type	Stages	Power		Current (A)	gal/h i/s	Head (ft)									
		kW	HP			0	5283	10567	15850	17171	18492	19813	21134	22455	
A6X 60 CR 05/01	1	4	5,5	8,4	69	62	52	46	43	39	39	36	30		
A6X 60 CR 07/02	2	5,5	7,5	11,3	141	128	108	89	85	82	75	69	62		
A6X 60 CR 12/03	3	9,3	12,5	17,4	210	190	161	135	128	121	115	105	92		
A6X 60 CR 15/04	4	11	15	19,6	279	253	213	180	171	164	151	138	121		
A6X 60 CR 20/05	5	15	20	27,3	351	318	266	223	213	203	190	174	151		
A6X 60 CR 25/06	6	18,5	25	34,5	420	381	322	269	256	243	226	207	184		
A6X 60 CR 30/07	7	22	30	40,1	489	443	374	315	302	285	266	243	213		
A6X 60 CR 30/08	8	22	30	40,1	558	509	427	361	344	325	305	276	243		
A6X 60 CR 35/09	9	26,5	35	47,1	630	571	479	404	387	364	341	312	276		
A6X 60 CR 40/10	10	30	40	51	699	636	535	449	430	407	381	348	305		
A6X 60 CR 40/11	11	30	40	51	768	699	587	495	472	446	417	381	335		

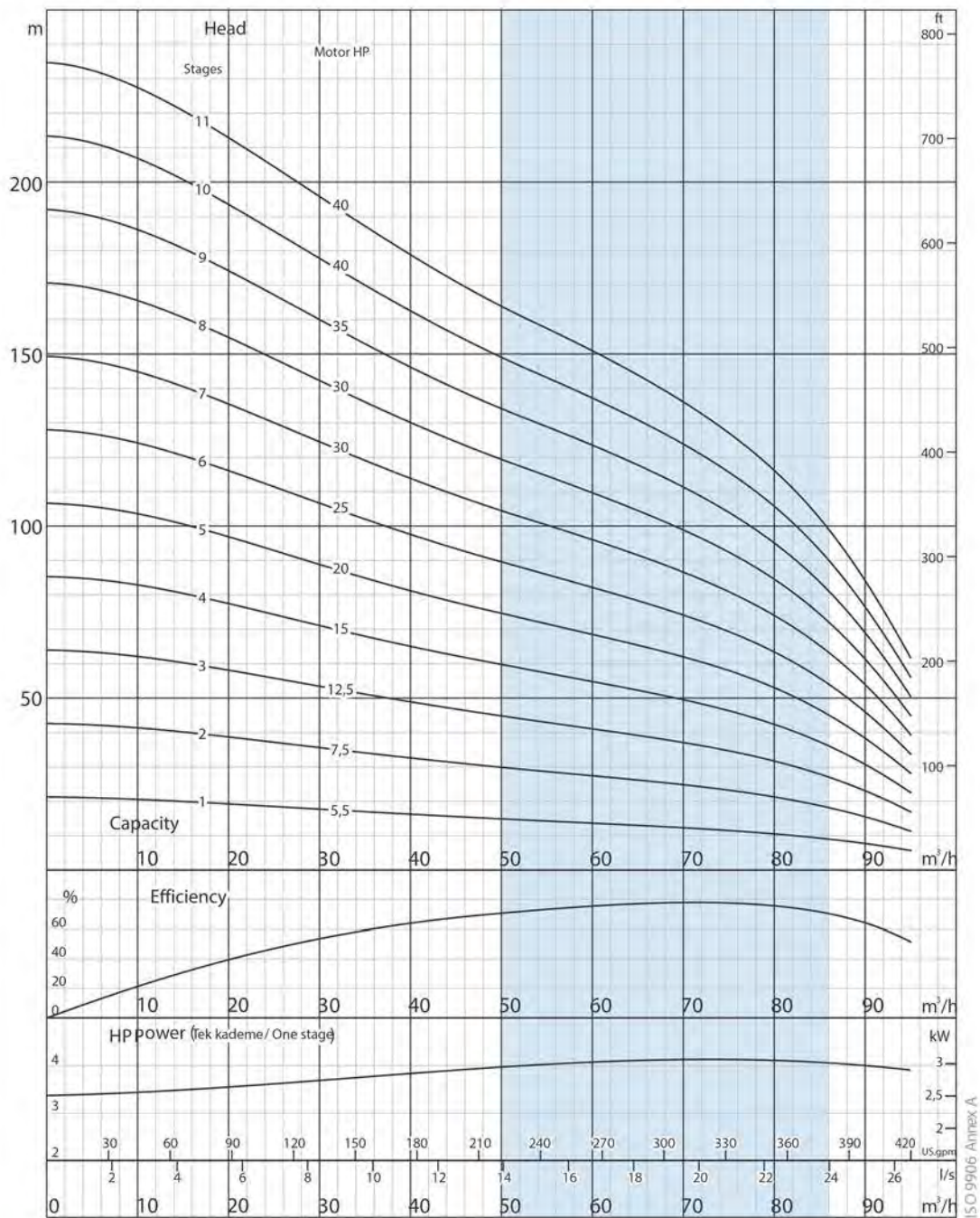

ISO 9906 Annex A

Due to continuous improvement in design we reserve the right to amend specifications or data without prior notice.

A6X 60 CR

No. of vanes
7

Outlet connection diameter
4" (inside threaded)

Pump outside diameter
144 mm

Rotation
CCW

Revolution
3500 rpm

Shaft diameter
22 mm



The hydraulic working characteristics have been taken with water at 15 °C, at the atmospheric pressure of 1 bar and specific gravity is 1 gr/cm³

Technical specifications

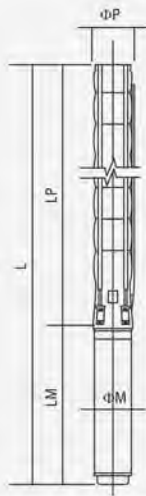

- Diffuser** : Stainless steel (AISI 304L)
- Impeller** : Stainless steel (AISI 304L)
- Pump shaft** : Stainless steel (AISI 420)
- Coupling** : Stainless steel (AISI 420)
- Strainer** : Stainless steel (AISI 304)
- Outlet connection diameter** : 4" (inside threaded)

- Max. sand content** : 50 gr / m³
- Valve cap** : Stainless steel
- Voltage** : 460 V (+%6 / -%10)
- Frequency** : 60 Hz.
- Max. water temperature** : 30°C (50°C optional)
- Degree of protection** : IP 68



Pump type	Stages	Power		Dimensions (in)					Weight (lb)		
		kW	HP	L	LM	LP	ΦM	ΦP	Motor	Pump	Total
A6X 60 CR 50/12	12	37	50	117 / 105 / 107	53 / 42 / 44	64	6 / 7 / 8	5	243 / 249 / 304	79	322 / 328 / 384
A6X 60 CR 50/13	13	37	50	121 / 110 / 112	53 / 42 / 44	68	6 / 7 / 8	5	243 / 249 / 304	86	328 / 335 / 390
A6X 60 CR 60/14	14	45	60	117 / 120	45 / 47	72	7 / 8	5	280 / 335	93	373 / 428
A6X 60 CR 60/15	15	45	60	122 / 124	45 / 47	77	7 / 8	5	280 / 335	97	377 / 432
A6X 60 CR 60/16	16	45	60	126 / 128	45 / 47	81	7 / 8	5	280 / 335	104	384 / 439
A6X 60 CR 70/17	17	52	70	134 / 136	48 / 51	86	7 / 8	5	304 / 375	110	414 / 485
A6X 60 CR 75/18	18	55	75	141	51	90	8	5	375	115	489
A6X 60 CR 75/19	19	55	75	145	51	94	8	5	375	121	496
A6X 60 CR 75/20	20	55	75	149	51	99	8	5	375	128	503
A6X 60 CR 80/21	21	60	80	156	53	103	8	5	408	132	540

Pump type	Stages	Power		Current (A)	gal/h l/s	Head (ft)									
		kW	HP			0	5283	10567	15850	17171	18492	19813	21134	22455	
A6X 60 CR 50/12	12	37	50	61,4	840	761	640	538	515	489	456	417	364		
A6X 60 CR 50/13	13	37	50	61,4	909	827	692	584	558	528	492	449	397		
A6X 60 CR 60/14	14	45	60	74,8	978	889	748	630	600	568	531	486	427		
A6X 60 CR 60/15	15	45	60	74,8	1050	951	801	673	643	610	568	518	456		
A6X 60 CR 60/16	16	45	60	74,8	1119	1017	853	719	686	650	607	554	489		
A6X 60 CR 70/17	17	52	70	85,3	1188	1079	906	764	728	689	646	591	518		
A6X 60 CR 75/18	18	55	75	90,2	1260	1142	961	810	771	732	682	623	548		
A6X 60 CR 75/19	19	55	75	90,2	1329	1207	1014	853	814	771	722	659	581		
A6X 60 CR 75/20	20	55	75	90,2	1398	1270	1066	899	856	814	758	692	610		
A6X 60 CR 80/21	21	60	80	99,6	1467	1332	1119	945	902	853	797	728	640		

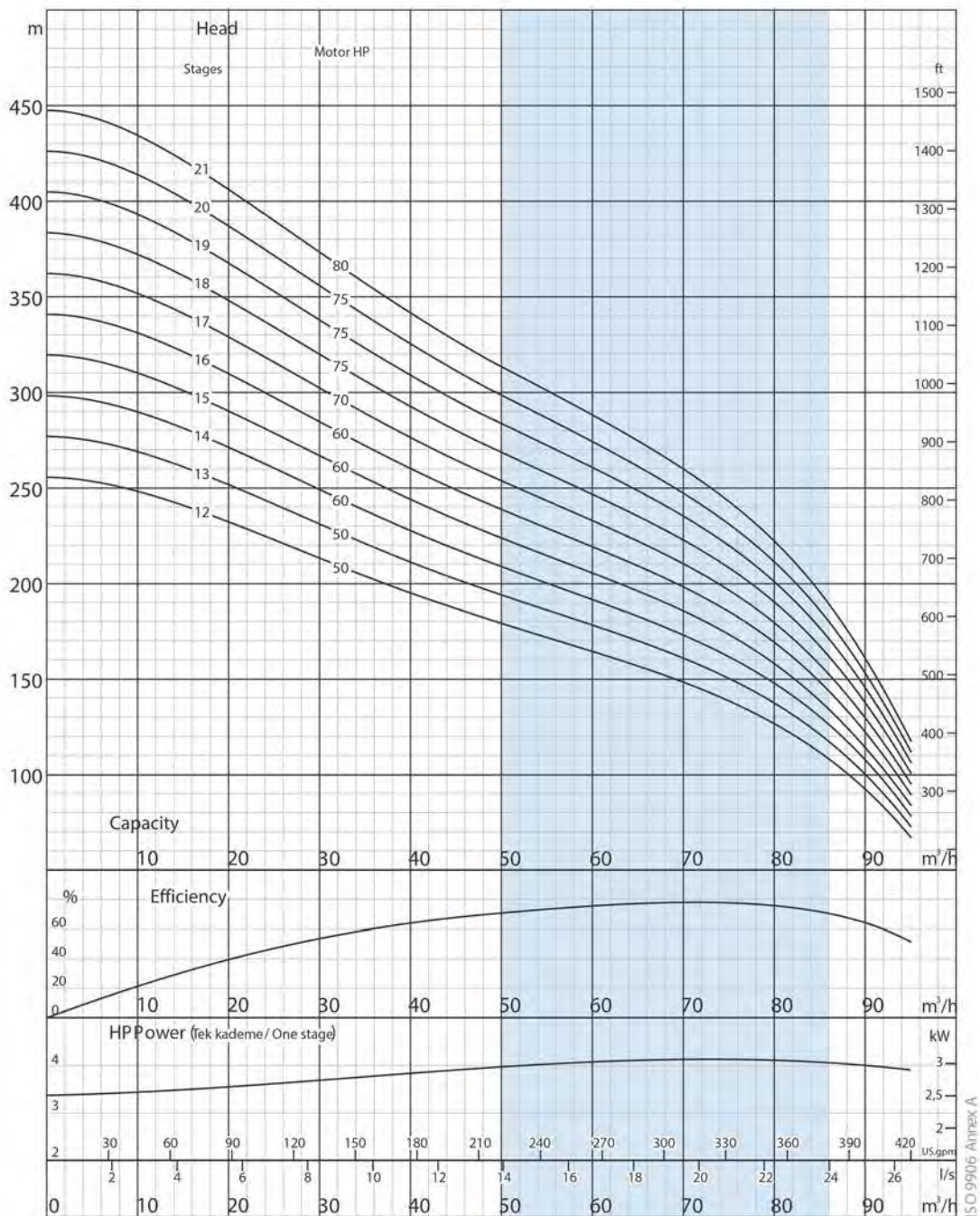

Due to continuous improvement in design we reserve the right to amend specifications or data without prior notice.

A6X 60 CR

No. of vanes
7

Outlet connection diameter
4" (inside threaded)

Pump outside diameter
144 mm

Rotation
CCW

Revolution
3500 rpm

Shaft diameter
22 mm

The hydraulic working characteristics have been taken with water at 15 °C, at the atmospheric pressure of 1 bar and specific gravity is 1 gr/cm³.



Technical specifications

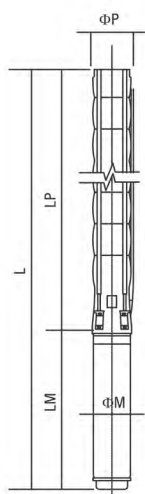

- Diffuser** : Stainless steel (AISI 304L)
- Impeller** : Stainless steel (AISI 304L)
- Pump shaft** : Stainless steel (AISI 420)
- Coupling** : Stainless steel (AISI 420)
- Strainer** : Stainless steel (AISI 304)
- Outlet connection diameter** : 5" (inside threaded)

- Max. sand content** : 50 gr / m³
- Valve cap** : Stainless steel
- Voltage** : 460 V (+%6 / -%10)
- Frequency** : 50 Hz.
- Max. water temperature** : 30°C (50°C optional)
- Degree of protection** : IP 68



Pump type	Stages	Power		Dimensions (in)					Weight (lb)		
		kW	HP	L	LM	LP	ΦM	ΦP	Motor	Pump	Total
A7X 77 CR 07/01	1	5,5	7,5	49	27	22	6	5	96	57	153
A7X 77 CR 15/02	2	11	15	61	34	28	6	5	132	66	198
A7X 77 CR 15/03	3	18,5	15	72	40	33	6	5	168	75	243
A7X 77 CR 30/04	4	22	30	81 / 73	44 / 35	38	6 / 7	5	192 / 190	84	276 / 273
A7X 77 CR 35/05	5	26,5	35	91 / 80	48 / 37	43	6 / 7	5	216 / 201	93	309 / 293
A7X 77 CR 40/06	6	37	40	101 / 89 / 92	53 / 42 / 44	48	6 / 7 / 8	5	243 / 249 / 304	101	344 / 344 / 406
A7X 77 CR 50/07	7	37	50	106 / 94 / 97	53 / 42 / 44	53	6 / 7 / 8	5	243 / 249 / 304	110	353 / 359 / 414
A7X 77 CR 60/08	8	45	60	103 / 105	45 / 47	58	7 / 8	5	280 / 335	119	399 / 454
A7X 77 CR 75/09	9	55	75	113	51	63	8	5	375	128	503
A7X 77 CR 75/10	10	55	75	118	51	68	8	5	375	137	511
A7X 77 CR 90/11	11	67	90	127	54	73	8	5	410	146	556
A7X 77 CR 90/12	12	67	90	132	54	78	8	5	410	154	564
A7X 77 CR 100/13	13	75	100	138	55	83	8	5	430	163	593
A7X 77 CR 125/14	14	92	125	148 / 144	60 / 56	88	8 / 9	5	467 / 626	172	639 / 798
A7X 77 CR 125/15	15	92	125	154 / 149	60	93	8 / 9	5	467 / 626	181	648 / 807

Pump type	Stages	Power		Current (A)	gal/h l/s	Head (ft)												
		kW	HP			0	7925	15850	18492	21134	23776	26417	29059	31701				
A7X 77 CR 07/01	1	5,5	7,5	11,3	92	85	75	72	69	62	56	49	39					
A7X 77 CR 15/02	2	11	15	19,6	180	174	154	144	135	125	112	98	79					
A7X 77 CR 15/03	3	18,5	15	34,5	272	259	230	217	203	187	167	144	118					
A7X 77 CR 30/04	4	22	30	40,1	364	344	308	292	272	249	223	194	157					
A7X 77 CR 35/05	5	26,5	35	47,1	453	433	384	364	341	312	282	243	200					
A7X 77 CR 40/06	6	37	40	61,4	545	518	463	436	407	374	338	292	240					
A7X 77 CR 50/07	7	37	50	61,4	636	604	538	509	476	436	394	341	279					
A7X 77 CR 60/08	8	45	60	74,8	725	692	614	581	545	499	449	390	318					
A7X 77 CR 75/09	9	55	75	90,2	817	778	692	653	610	561	505	436	358					
A7X 77 CR 75/10	10	55	75	90,2	909	863	768	728	679	623	561	486	397					
A7X 77 CR 90/11	11	67	90	111,2	997	951	846	801	748	689	617	535	436					
A7X 77 CR 90/12	12	67	90	111,2	1089	1037	922	873	817	751	673	584	476					
A7X 77 CR 100/13	13	75	100	123,1	1181	1122	997	945	883	814	728	633	518					
A7X 77 CR 125/14	14	92	125	149,4	1270	1211	1076	1017	951	876	787	682	558					
A7X 77 CR 125/15	15	92	125	149,4	1362	1296	1152	1089	1020	938	843	728	597					

Performance Table

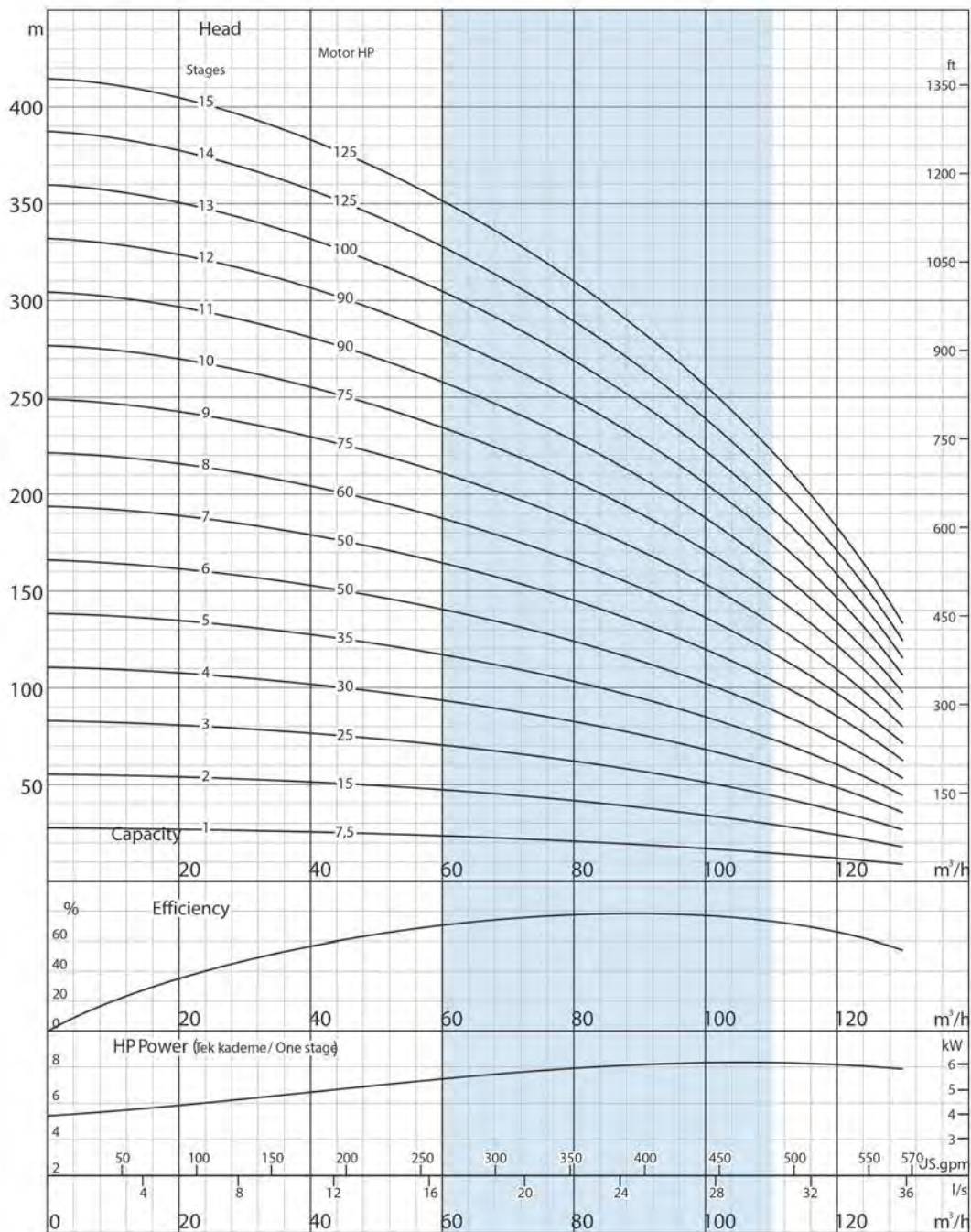

ISO 9906 Annex A

Due to continuous improvement in design we reserve the right to amend specifications or data without prior notice.

A7X 77 CR

No. of vanes
6

Outlet connection diameter
5" (inside threaded)

Pump outside diameter
172 mm

Rotation
CCW

Revolution
3500 rpm

Shaft diameter
25,4 mm

The hydraulic working characteristics have been taken with water at 15 °C, at the atmospheric pressure of 1 bar and specific gravity is 1 gr/cm³



Technical specifications

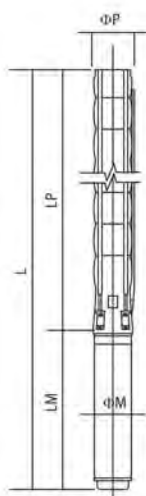

- Diffuser** : Stainless steel (AISI 304L)
- Impeller** : Stainless steel (AISI 304L)
- Pump shaft** : Stainless steel (AISI 420)
- Coupling** : Stainless steel (AISI 420)
- Strainer** : Stainless steel (AISI 304)
- Outlet connection diameter** : 5" (inside threaded)

- Max. sand content** : 50 gr / m³
- Valve cap** : Stainless steel
- Voltage** : 460 V (+%6 / -%10)
- Frequency** : 60 Hz.
- Max. water temperature** : 30°C (50°C optional)
- Degree of protection** : IP 68



Pump type	Stages	Power		Dimensions (in)					Weight (lb)		
		kW	HP	L	LM	LP	ΦM	ΦP	Motor	Pump	Total
A7X 95 CR 12/01	1	9,3	12,5	54	31	22	6	5	121	57	179
A7X 95 CR 25/02	2	18,5	25	67	40	28	6	5	168	66	234
A7X 95 CR 35/03	3	26,5	35	80 / 70	48 / 37	33	6 / 7	5	216 / 201	75	291 / 276
A7X 95 CR 50/04	4	37	50	91 / 79 / 82	53 / 42 / 44	38	6 / 7 / 8	5	243 / 249 / 304	84	326 / 333 / 388
A7X 95 CR 60/05	5	45	60	87 / 90	45 / 47	43	7 / 8	5	280 / 335	93	372 / 428
A7X 95 CR 70/06	6	52	70	96 / 98	48 / 51	48	7 / 8	5	304 / 375	101	406 / 476
A7X 95 CR 80/07	7	60	80	106	53	53	8	5	408	110	518
A7X 95 CR 90/08	8	67	90	112	54	58	8	5	410	119	529
A7X 95 CR 100/09	9	75	100	118	55	63	8	5	430	128	558
A7X 95 CR 110/10	10	81	110	126 / 122	58 / 54	68	8 / 9	5	463 / 564	137	600 / 701
A7X 95 CR 125/11	11	92	125	133 / 129	60 / 56	73	8 / 9	5	467 / 626	146	613 / 772

Pump type	Stages	Power		Current (A)	gal/h i/s	Head (ft)									
		kW	HP			0	5283	10567	18492	23775	26417	29059	31701	34342	
A7X 95 CR 12/01	1	9,3	12,5	17,4	Head (ft)	118	105	89	85	82	79	75	69	62	
A7X 95 CR 25/02	2	18,5	25	34,5		236	207	177	171	164	157	148	138	125	
A7X 95 CR 35/03	3	26,5	35	47,1		354	312	266	256	246	233	223	207	184	
A7X 95 CR 50/04	4	37	50	61,4		472	417	358	341	325	312	295	276	246	
A7X 95 CR 60/05	5	45	60	74,8		591	518	446	427	407	390	371	344	308	
A7X 95 CR 70/06	6	52	70	85,3		709	623	535	512	489	469	446	413	371	
A7X 95 CR 80/07	7	60	80	99,6		827	728	623	597	571	548	518	482	433	
A7X 95 CR 90/08	8	67	90	111,2		945	830	712	682	653	627	594	551	492	
A7X 95 CR 100/09	9	75	100	123,1		1063	935	801	768	735	702	666	620	554	
A7X 95 CR 110/10	10	81	110	131,5		1181	1040	889	850	817	781	741	689	617	
A7X 95 CR 125/11	11	92	125	149,4		1299	1142	981	935	899	860	817	758	679	

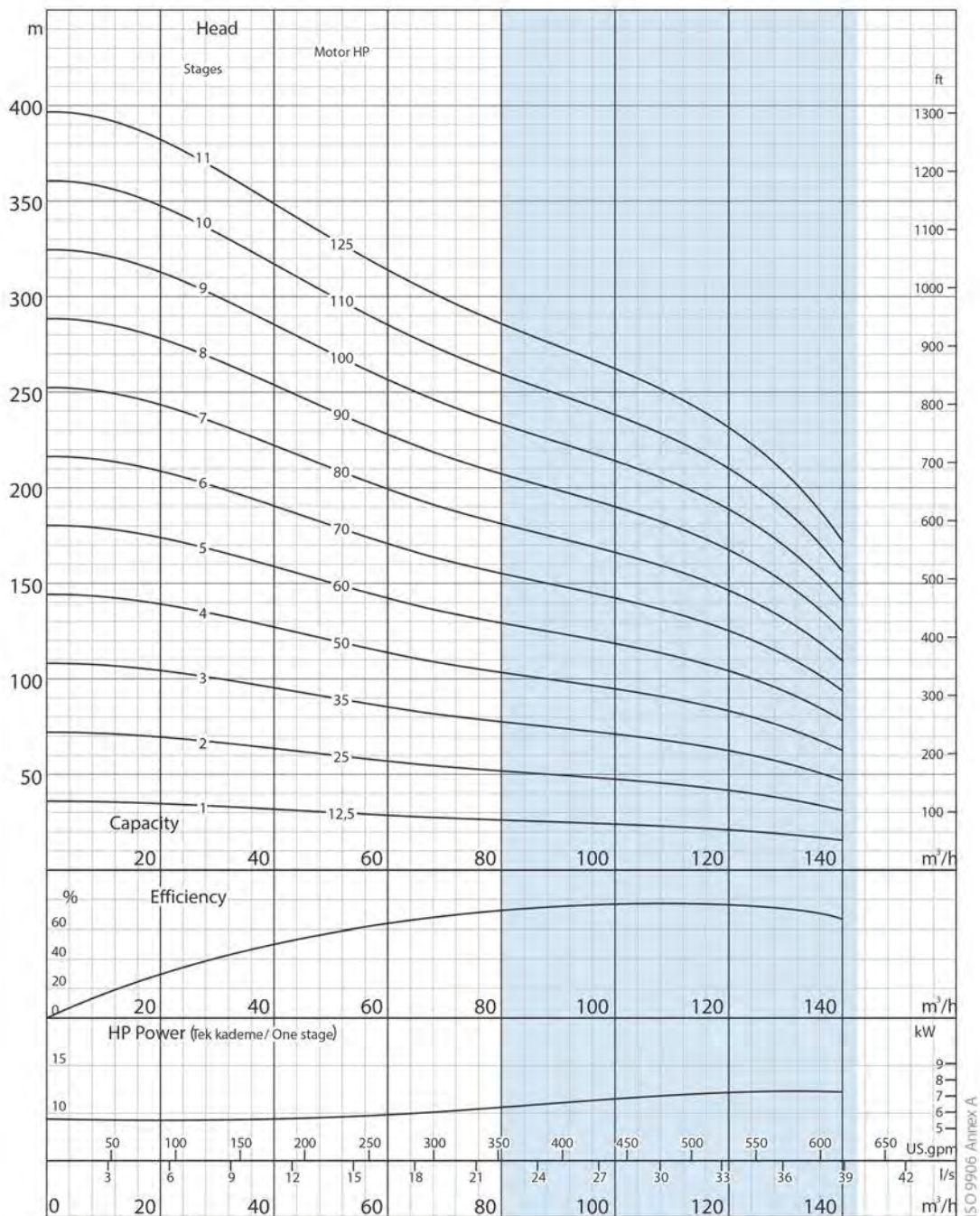

ISO 9906 Annex A

Due to continuous improvement in design we reserve the right to amend specifications or data without prior notice.

A7X 95 CR

No. of vanes
7

Outlet connection diameter
5" (inside threaded)

Pump outside diameter
172 mm

Rotation
CCW

Revolution
3500 rpm

Shaft diameter
25,4 mm

The hydraulic working characteristics have been taken with water at 15 °C, at the atmospheric pressure of 1 bar and specific gravity is 1 gr/cm³



Technical specifications

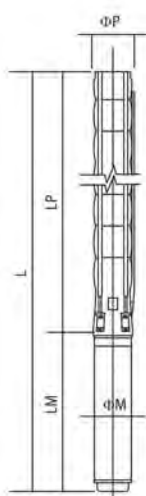

- Diffuser** : Stainless steel (AISI 304L)
- Impeller** : Stainless steel (AISI 304L)
- Pump shaft** : Stainless steel (AISI 420)
- Coupling** : Stainless steel (AISI 420)
- Strainer** : Stainless steel (AISI 304)
- Outlet connection diameter** : 5" (inside threaded)

- Max. sand content** : 50 gr / m³
- Valve cap** : Stainless steel
- Voltage** : 460 V (+%6 / -%10)
- Frequency** : 60 Hz.
- Max. water temperature** : 30°C (50°C optional)
- Degree of protection** : IP 68



Pump type	Stages	Power		Dimensions (in)					Weight (lb)		
		kW	HP	L	LM	LP	ΦM	ΦP	Motor	Pump	Total
A8X 110 CR17/01	1	13	17,5	63	36	27	6	5	143	71	214
A8X 110 CR35/02	2	26,5	35	81 / 70	48/37	33	6/7	5	216 / 201	84	300 / 284
A8X 110 CR50/03	3	37	50	92 / 81 / 83	53 / 42 / 44	39	6 / 7 / 8	5	243 / 249 / 304	99	342 / 348 / 403
A8X 110 CR60/04	4	45	60	90 / 93	45 / 47	45	7 / 8	5	280 / 335	112	392 / 448
A8X 110 CR80/05	5	60	80	104	53	52	8	5	408	126	534
A8X 110 CR90/06	6	67	90	111	54	58	8	5	410	141	551
A8X 110 CR110/07	7	81	110	122 / 118	58 / 54	64	8 / 9	5	463 / 564	154	617 / 719
A8X 110 CR125/08	8	92	125	130 / 126	60 / 56	70	8 / 9	5	467 / 626	168	617 / 794
A8X 110 CR150/09	9	110	150	136	59	76	9	5	686	183	869
A8X 110 CR110/10	10	110	150	142	59	82	9	5	686	196	882
A8X 110 CR175/11	11	129	175	152	63	88	9	5	745	209	955
A8X 110 CR175/12	12	129	175	158	63	94	9	5	745	223	968
A8X 110 CR200/13	13	147	200	169	69	101	9	5	816	238	1054
A8X 110 CR225/14	14	166	225	178	72	107	9	5	882	251	1133
A8X 110 CR225/15	15	166	225	184	72	113	9	5	882	265	1146

Pump type	Stages	Power		Current (A)	gal/h i/s	Head (ft)													
		kW	HP			0	13209	26417	29059	31701	34342	36984	39626	42268					
A8X 110 CR17/01	1	13	17,5	23,4		131	118	102	98	92	85	82	72	66					
A8X 110 CR35/02	2	26,5	35	47,1		259	236	203	194	184	174	161	148	131					
A8X 110 CR50/03	3	37	50	61,4		390	351	305	292	276	259	243	220	197					
A8X 110 CR60/04	4	45	60	74,8		518	469	404	387	367	348	322	295	262					
A8X 110 CR80/05	5	60	80	99,6		650	587	505	486	463	433	404	367	328					
A8X 110 CR90/06	6	67	90	111,2		778	705	607	581	554	522	486	443	397					
A8X 110 CR110/07	7	81	110	131,5		909	823	709	679	646	607	564	515	463					
A8X 110 CR125/08	8	92	125	149,4		1040	942	810	778	738	696	646	591	528					
A8X 110 CR150/09	9	110	150	180,5		1168	1056	912	873	830	781	725	663	594					
A8X 110 CR150/10	10	110	150	180,5		1299	1175	1014	971	922	869	807	738	659					
A8X 110 CR175/11	11	129	175	207		1427	1293	1115	1066	1014	955	889	810	725					
A8X 110 CR175/12	12	129	175	207		1558	1411	1214	1165	1106	1043	968	886	791					
A8X 110 CR200/13	13	147	200	236		1686	1529	1316	1260	1198	1129	1050	958	856					
A8X 110 CR225/14	14	166	225	266,2		1818	1644	1417	1358	1293	1217	1132	1033	922					
A8X 110 CR225/15	15	166	225	266,2		1946	1762	1519	1457	1385	1302	1211	1106	988					

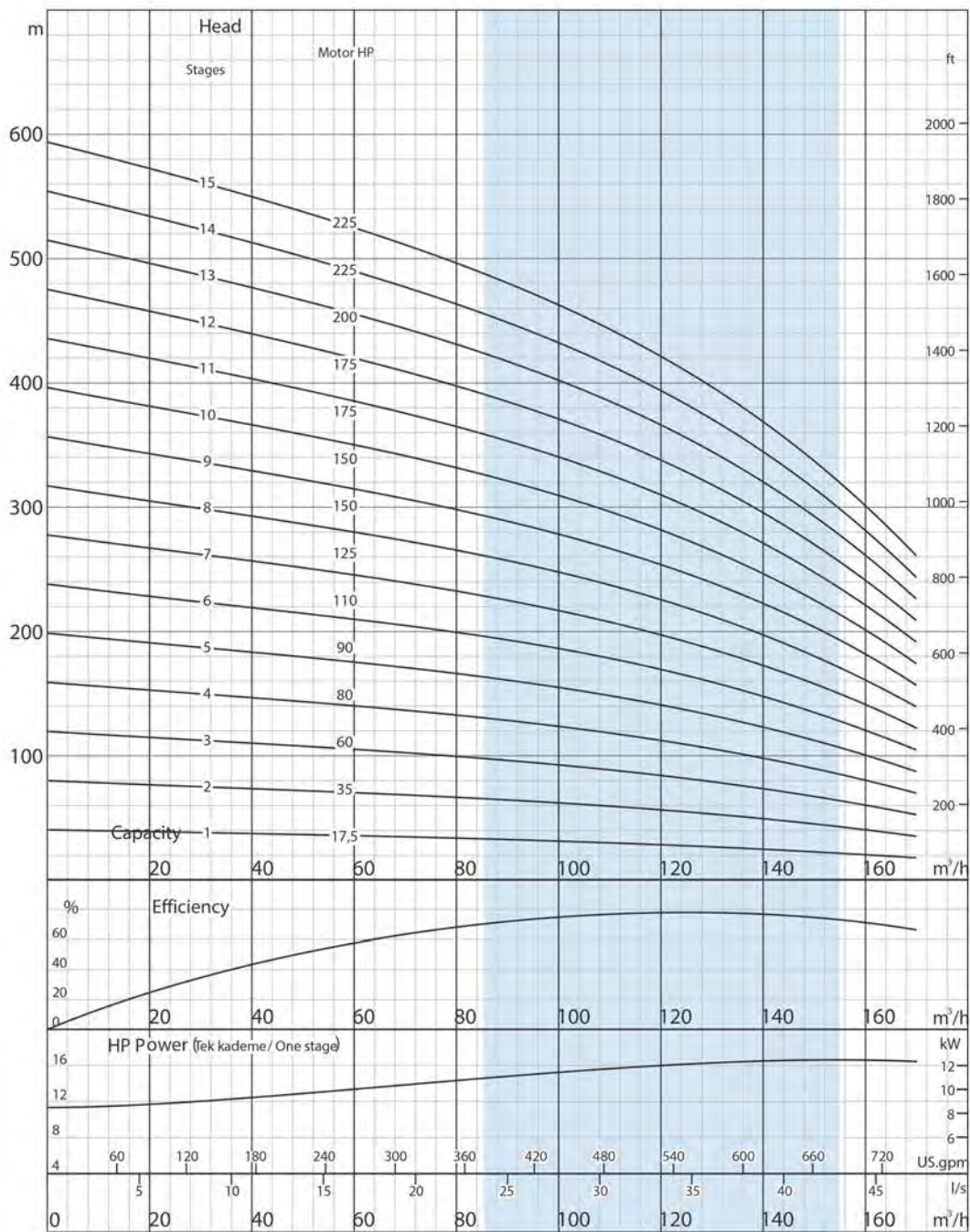

Due to continuous improvement in design we reserve the right to amend specifications without prior notice.

A8X 110 CR

No. of vanes	7	Rotation	CCW
Outlet connection diameter	5" (inside threaded)	Revolution	3500 rpm
Pump outside diameter	172 mm	Shaft diameter	25,4 mm

The hydraulic working characteristics have been taken with water at 15 °C, at the atmospheric pressure of 1 bar and specific gravity is 1 gr/cm³.



Technical specifications

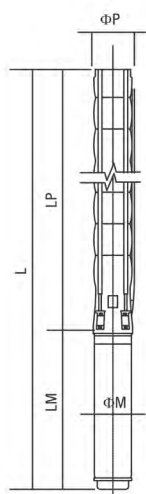

- Diffuser** : Stainless steel (AISI 304L)
- Impeller** : Stainless steel (AISI 304L)
- Pump shaft** : Stainless steel (AISI 420)
- Coupling** : Stainless steel (AISI 420)
- Strainer** : Stainless steel (AISI 304)
- Outlet connection diameter** : 6" (inside threaded)

- Max. sand content** : 50 gr / m³
- Valve cap** : Stainless steel
- Voltage** : 460 V (+%6 / -%10)
- Frequency** : 60 Hz.
- Max. water temperature** : 30°C (50°C optional)
- Degree of protection** : IP 68



Pump type	Stages	Power		Dimensions (in)					Weight (lb)		
		kW	HP	L	LM	LP	ΦM	ΦP	Motor	Pump	Total
A8X 125 CR25/01	1	18,5	25	67	40	27	6	5	168	71	238
A8X 125 CR40/02.B1	2	30	40	82 / 72 / 75	49 / 39 / 42	33	6 / 7 / 8	5	227/227/284	86	313/313/370
A8X 125 CR40/02	2	30	40	82 / 72 / 75	49 / 39 / 42	33	6 / 7 / 8	5	227/227/284	86	313/313/370
A8X 125 CR60/03.B1	3	45	60	84 / 87	45 / 47	39	7 / 8	5	280/335	99	379/434
A8X 125 CR70/03	3	52	70	87 / 90	48 / 51	39	7 / 8	5	304/375	99	403/474
A8X 125 CR90/04	4	67	90	99	54	45	8	5	410	115	525
A8X 125 CR100/05.B1	5	75	100	106	55	52	8	5	430	128	558
A8X 125 CR125/05	5	92	125	112 / 108	60 / 56	52	8 / 9	5	467/626	128	595/754
A8X 125 CR125/06	6	92	125	118 / 114	60 / 56	58	8 / 9	5	467/626	143	611/769
A8X 125 CR150/07	7	110	150	123	59	64	9	5	686	157	842
A8X 125 CR175/08	8	132	175	133	63	70	9	5	745	172	917
A8X 125 CR175/09B2	9	132	175	139	63	76	9	5	745	185	930
A8X 125 CR200/09	9	147	200	145	69	76	9	5	816	185	1001
A8X 125 CR200/10B2	10	147	200	151	69	82	9	5	816	201	1016
A8X 125 CR225/10	10	166	225	154	72	82	9	5	882	201	1082
A8X 125 CR225/11	11	166	225	160	72	88	9	5	882	214	1096

Pump type	Stages	Power		Current (A)	gal/h l/s	Head (ft)								
		kW	HP			0,00	11,11	33,33	36,11	38,89	41,67	44,44	47,22	50,00
A8X 125 CR25/01	1	18,5	25	34,5	Head(ft)	151	144	118	115	112	105	98	92	85
A8X 125 CR40/02.B1	2	30	40	51		289	272	223	213	203	194	180	167	154
A8X 125 CR40/02	2	30	40	51		305	289	240	230	220	210	197	184	171
A8X 125 CR60/03.B1	3	45	60	74,8		440	417	341	328	315	299	282	262	240
A8X 125 CR70/03	3	52	70	85,3		456	433	358	344	331	315	299	279	256
A8X 125 CR90/04	4	67	90	111,2		607	577	476	459	440	420	397	371	341
A8X 125 CR100/05.B1	5	75	100	123,1		741	709	581	558	535	509	479	446	410
A8X 125 CR125/05	5	92	125	149,4		758	725	594	574	551	525	495	463	427
A8X 125 CR125/06	6	92	125	149,4		912	869	715	689	659	630	594	554	512
A8X 125 CR150/07	7	110	150	180,5		1063	1014	833	804	771	735	692	650	597
A8X 125 CR175/08	8	132	175	207		1214	1158	951	919	879	840	794	741	682
A8X 125 CR175/09B2	9	132	175	207		1335	1270	1040	1001	958	912	860	801	735
A8X 125 CR200/09	9	147	200	236		1368	1302	1070	1033	991	942	892	833	768
A8X 125 CR200/10B2	10	147	200	236		1486	1414	1158	1115	1070	1017	958	892	820
A8X 125 CR225/10	10	166	225	266,2	1519	1447	1191	1145	1099	1047	991	925	853	
A8X 125 CR225/11	11	166	225	266,2	1670	1591	1309	1260	1211	1152	1089	1017	938	

Performance Table

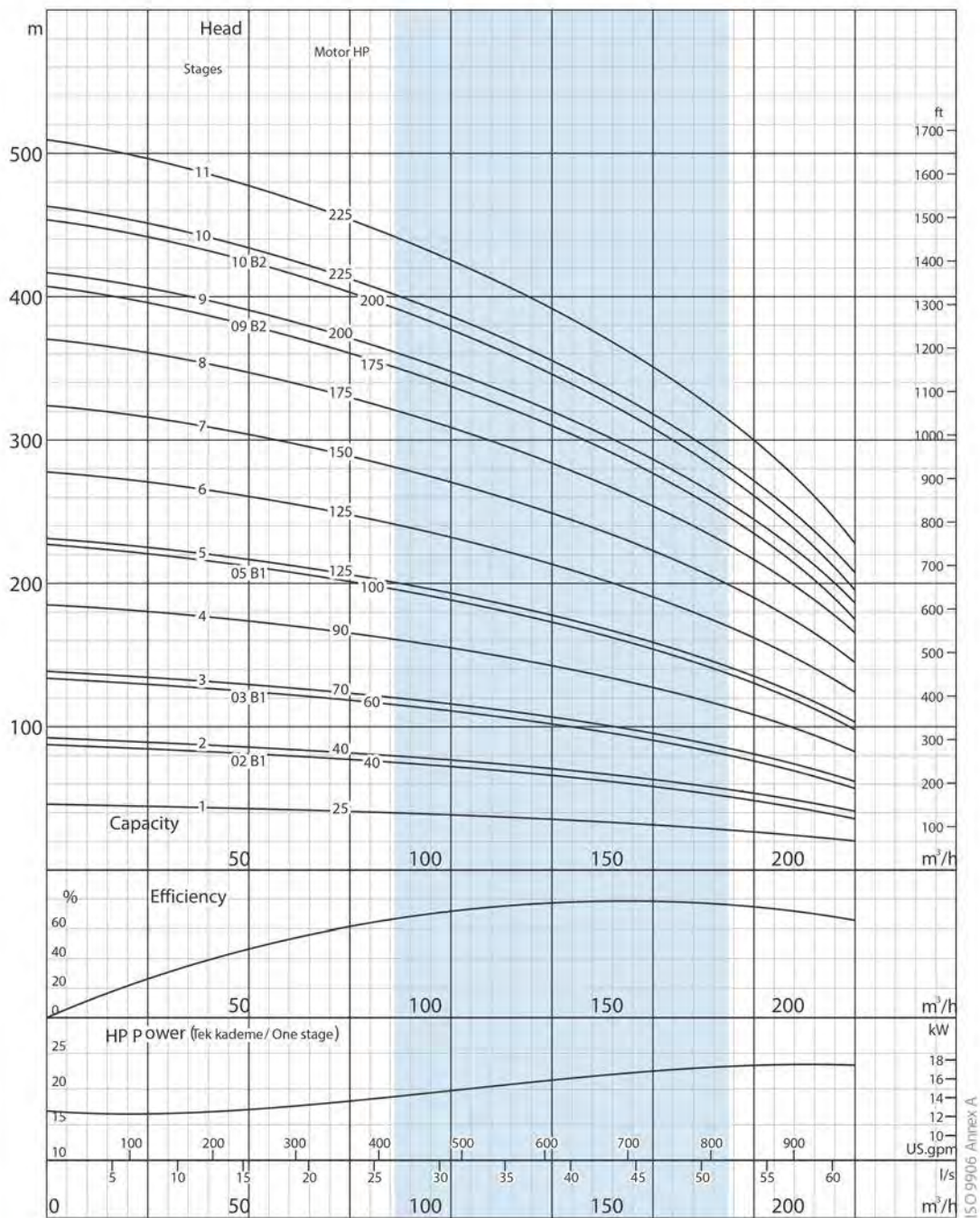

Due to continuous improvement in design we reserve the right to amend specifications or data without prior notice.

A8X 125 CR

No. of vanes	7	Rotation	CCW
Outlet connection diameter	6" (inside threaded)	Revolution	3500 rpm
Pump outside diameter	213 mm	Shaft diameter	30,16 mm



The hydraulic working characteristics have been taken with water at 15 °C, at the atmospheric pressure of 1 bar and specific gravity is 1 gr/cm³

Technical specifications

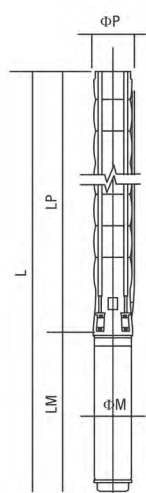

Diffuser : Stainless steel (AISI 304L)
Impeller : Stainless steel (AISI 304L)
Pump shaft : Stainless steel (AISI 420)
Coupling : Stainless steel (AISI 420)
Strainer : Stainless steel (AISI 304)
Outlet connection diameter : 6" (inside threaded)

Max. sand content : 50 gr / m³
Valve cap : Stainless steel
Voltage : 460 V (+%6 / -%10)
Frequency : 60 Hz.
Max. water temperature : 30°C (50°C optional)
Degree of protection : IP 68



Pump type	Stages	Power		Dimensions (in)					Weight (lb)		
		kW	HP	L	LM	LP	ΦM	ΦP	Motor Motor	Pompa Pump	Toplam Total
A10X 160CR30/01	1	22	30	71 / 62	44 / 35	27	6 / 7	5	192 / 190	75	267 / 265
A10X16 0CR50/02	2	37	50	86 / 75 / 77	53 / 42 / 44	33	6 / 7 / 8	5	242 / 249 / 304	88	331 / 337 / 392
A10X16 0CR75/03	3	55	75	90	51	39	8	5	375	104	478
A10X16 0CR100/04	4	75	100	100	55	45	8	5	430	117	547
A10X16 0CR125/05	5	92	125	112 / 108	60 / 56	52	8 / 9	5	467 / 626	132	600 / 758
A10X16 0CR150/06	6	110	150	117	59	58	9	5	686	146	831
A10X16 0CR175/07	7	132	175	127	63	64	9	5	745	161	906
A10X16 0CR200/08	8	147	200	138	69	70	9	5	816	174	990
A10X16 0CR225/09	9	166	225	148	72	76	9	5	882	190	1071

Pump type	Stages	Power		Current (A)	gal/h l/s	0	13209	34342	39626	44909	50193	55476	60760	66043
		kW	HP			0,00	13,89	36,11	41,67	47,22	52,78	58,33	63,89	69,44
A10X16 0CR30 / 01	1	22	30	40,1	Head (ft)	144	135	108	105	98	89	79	69	52
A10X16 0CR50 / 02	2	37	50	61,4		289	269	220	207	194	180	161	135	105
A10X16 0CR75/03	3	55	75	90,2		436	404	328	312	292	269	240	203	157
A10X16 0CR100/04	4	75	100	123,1		581	535	436	413	390	361	322	272	210
A10X16 0CR125/05	5	92	125	149,4		725	669	545	518	486	449	400	338	262
A10X16 0CR150/06	6	110	150	180,5		869	804	656	620	584	538	482	407	315
A10X16 0CR175/07	7	132	175	207		1014	938	764	725	682	630	561	472	371
A10X16 0CR200/08	8	147	200	236		1161	1073	873	827	781	719	643	541	423
A10X16 0CR225/09	9	166	225	266,2		1306	1207	981	932	876	810	722	610	476

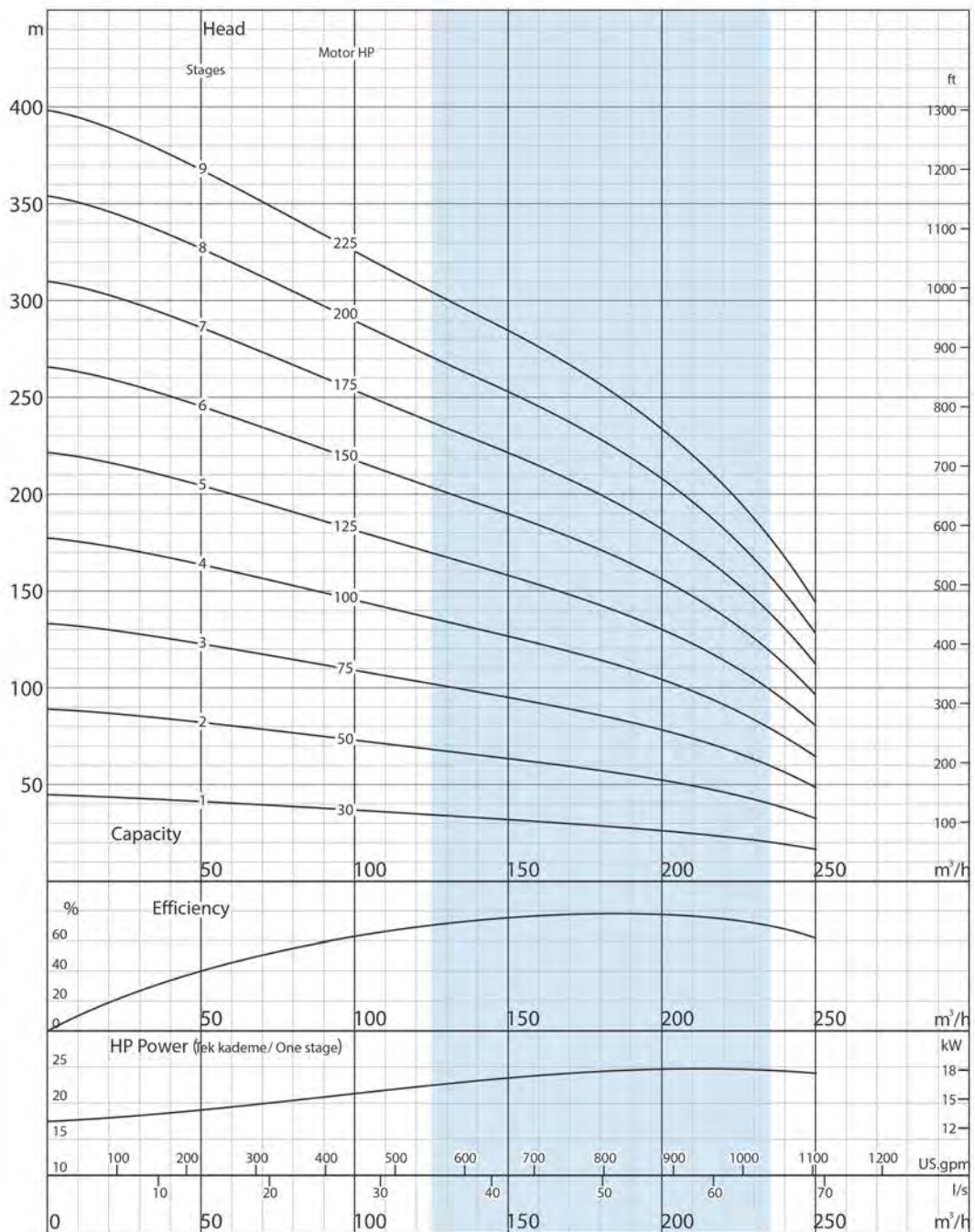

ISO 9906 Annex A

Due to continuous improvement in design we reserve the right to amend specifications or data without prior notice.

A10X 160 CR

No. of vanes
6

Outlet connection diameter
6" (inside threaded)

Pump outside diameter
226 mm

Rotation
CCW

Revolution
3500 rpm

Shaft diameter
30,16 mm



The hydraulic working characteristics have been taken with water at 15 °C, at the atmospheric pressure of 1 bar and specific gravity is 1 gr/cm³

Technical specifications

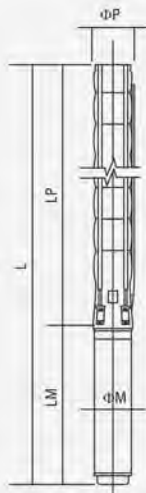

Diffuser	: Stainless steel (AISI 304L)
Impeller	: Stainless steel (AISI 304L)
Pump shaft	: Stainless steel (AISI 420)
Coupling	: Stainless steel (AISI 420)
Strainer	: Stainless steel (AISI 304)
Outlet connection diameter : 6" (inside threaded)	

Max. sand content	: 50 gr / m ³
Valve cap	: Stainless steel
Voltage	: 460 V (+ %6 / -%10)
Frequency	: 60 Hz.
Max. water temperature	: 30°C (50°C optional)
Degree of protection	: IP 68



Pump type	Stages	Power		Dimensions (in)					Weight (lb)		
		kW	HP	L	LM	LP	ΦM	ΦP	Motor	Pump	Total
A10X21 0CR4001	1	30	40	80 / 70 / 73	49 / 39 / 42	31	6 / 7 / 8	5	227 / 227 / 284	97	324 / 324 / 381
A10X21 0CR8002	2	60	80	91	53	38	8	5	408	121	529
A10X21 0CR12503	3	92	125	106 / 101	60 / 56	45	8 / 9	5	467 / 626	146	613 / 772
A10X21 0CR15004	4	110	150	112	59	52	9	5	686	168	853
A10X21 0CR20005	5	147	200	128	69	59	9	5	816	192	1008
A10X21 0CR22506	6	166	225	138	72	66	9	5	882	216	1098

Pump type	Stages	Power		Current (A)	gal/h l/s	Head (ft)									
		kW	HP			0	26417	58118	63401	68685	73968	79252	84535	95102	
A10X21 0CR4001	1	30	40	51	Head (ft)	0,00	27,78	61,11	66,67	72,22	77,78	83,33	88,89	100,00	
A10X21 0CR8002	2	60	80	99,6		184	161	125	118	112	105	98	89	62	
A10X21 0CR12503	3	92	125	149,4		367	325	249	236	223	210	194	177	128	
A10X21 0CR15004	4	110	150	180,5		548	486	374	354	338	315	292	266	190	
A10X21 0CR20005	5	147	200	236		732	646	499	472	449	420	390	354	256	
A10X21 0CR22506	6	166	225	266,2		915	807	623	594	561	525	486	440	318	
						1099	971	748	712	673	630	584	528	384	

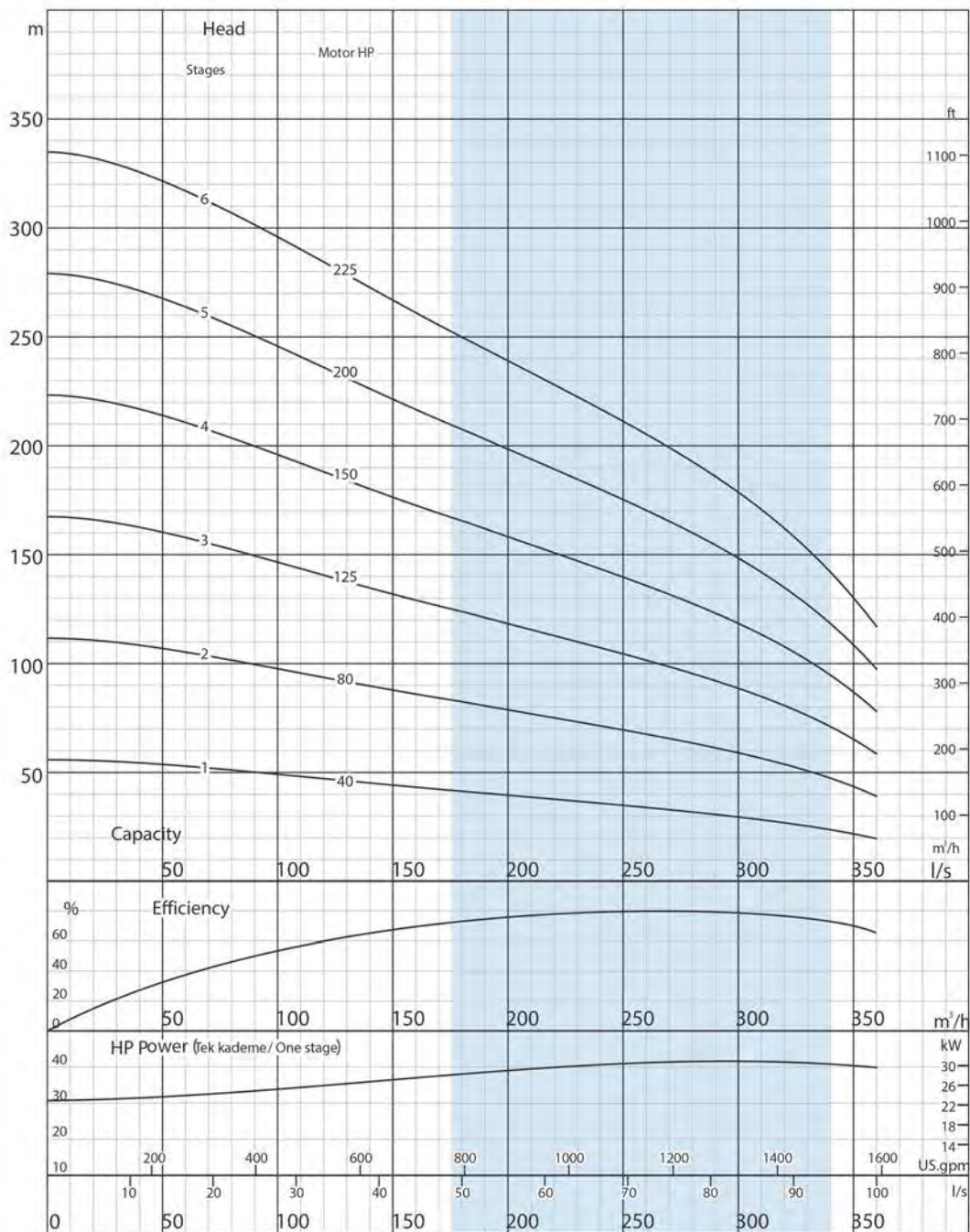

Due to continuous improvement in design we reserve the right to amend specifications or data without prior notice.

A10X 210 CR

No. of vanes
7

Outlet connection diameter
6" (inside threaded)

Pump outside diameter
247 mm

Rotation
CCW

Revolution
3500 rpm

Shaft diameter
42,86 mm



The hydraulic working characteristics have been taken with water at 15 °C, at the atmospheric pressure of 1 bar and specific gravity is 1 gr/cm³

(DOL)

HP	Cable Sizes										
	3x1,5	3x2,5	3x4	3x6	3x10	3x16	3x25	3x35	3x50	3x70	3x95
5,5	65	108	172	258	431	689	1.077	1.507	2.153	3.014	4.091
7,5	48	80	129	193	322	515	805	1.127	1.610	2.254	3.059
10	38	64	102	153	256	409	639	894	1.278	1.789	2.428
12,5		52	83	125	209	334	522	730	1.043	1.461	1.982
15		45	72	109	181	289	452	633	904	1.266	1.718
17,5			61	92	153	245	383	536	765	1.071	1.454
20			52	79	131	210	327	458	655	917	1.244
25					106	170	266	372	531	744	1.009
30					90	145	226	316	452	633	859
35					76	122	190	266	380	532	722
40					67	107	168	235	336	470	638
50						89	139	195	279	390	529
60							115	160	229	321	434
70								139	198	278	377
75								131	187	262	356
80								120	172	241	326
90									154	215	292
100									132	192	261
110									127	178	242
125										157	213
150											182
175											155
200											
210											
225											
250											

(Wye - Delta)

HP	Cable Sizes										
	3x1,5	3x2,5	3x4	3x6	3x10	3x16	3x25	3x35	3x50	3x70	3x95
5,5	97	161	258	388	646	1.033	1.615	2.261	3.230	4.521	6.136
7,5	72	121	193	290	483	773	1.207	1.690	2.415	3.381	4.588
10	57	96	153	230	383	613	958	1.342	1.916	2.683	3.641
12,5	47	78	125	188	313	501	783	1.096	1.565	2.191	2.974
15	41	68	109	163	271	434	678	949	1.356	1.899	2.577
17,5	34	57	92	138	230	367	574	803	1.148	1.607	2.181
20	29	49	79	118	196	314	491	688	982	1.375	1.867
25		40	64	96	159	255	398	558	797	1.115	1.514
30			54	81	136	217	339	475	678	949	1.288
35			46	68	114	182	285	399	570	798	1.083
40				60	101	161	252	352	503	705	956
50					84	134	209	293	418	585	794
60					69	110	172	241	344	481	653
70					59	95	149	208	297	416	565
75						90	141	197	281	394	534
80						82	129	180	258	361	490
90						74	115	162	231	323	439
100							103	144	206	289	392
110							95	134	191	267	363
125								118	168	235	319
150								101	144	201	273
175									123	172	233
200										152	207
210										145	196
225										136	184
250											164



GPT
CO

G.P.T.CO



GOL PUMPS TECHNOLOGY INC

3750 NW 114TH AVE SUITE #6 MIAMI, FL 33178

TEL : +1(786)615-8984 & +1(786)452-9775

FAX : +1(786)615-7043

GOLPUMPS.COM